

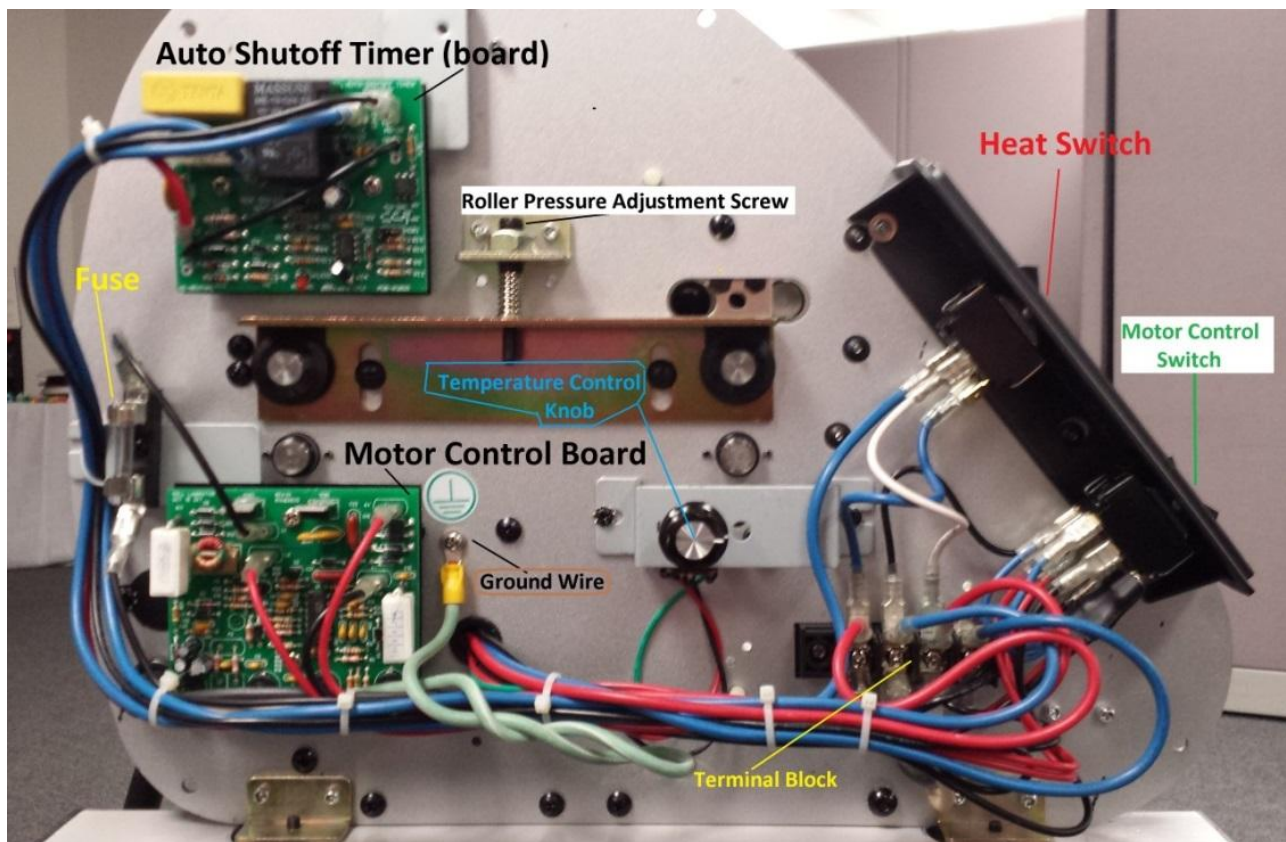

## Automatic Shut-off Timer Replacement Instructions

(for use with these USI Roll Laminators:

CSL 2700, ARL 1800, ARL 2700)



**NEWER MACHINES** (manufactured from September 2003 through the present; except ARL1800s – for ARL1800 refer to “Older Machine” tools):

**Tools required for newer Metric machines with serial numbers:** Classroom Blue 90001-0708 and up; Classroom Green 00001-0708 and up; Classroom Purple 10001-0708 and up.; ARL2700 40001-0708 and up or 50001-0708 and up; Cleartek WO665-0708 and up or GO909-0708 and up., Phillips screw driver, 3mm Allen wrench and additional for Classroom models, 2mm Allen wrench.

**OLDER MACHINES** (manufactured prior to September 2003 and includes all ARL 1800 machines)

**Tools required for US machines with serial numbers:** Classroom Blue 0602-0001 to 0805-0871; Classroom Green 0602-0001 to 0705-0878; Classroom Purple 0702-0001 to 0605-0743; ARL2700 0602-0001 to 0905-0950; **ARL1800 all**, Phillips screw driver, 5/32 Allen wrench and additional for Classroom models, 1/16 Allen wrench.

1. Unplug your machine from the power outlet.
2. **\*\*CSL ONLY\*\*** - Remove the temperature knob by turning it all the way to the left and loosening the 2mm Allen (or 1/16 US Allen for Older/US machines) set screw in the side 2-3 turns. Also be sure to pull out the thermometer. (see pictures below)



3. Remove the left side housing (blue plastic cover) by unscrewing the four black **3mm metric Allen Head screws**. (US machines from **mid 2007 and earlier** use **US Allen Wrench size 5/32"** – These machine have 8 digit serial numbers – compared to 9 digit serial numbers on later models. (see picture below)

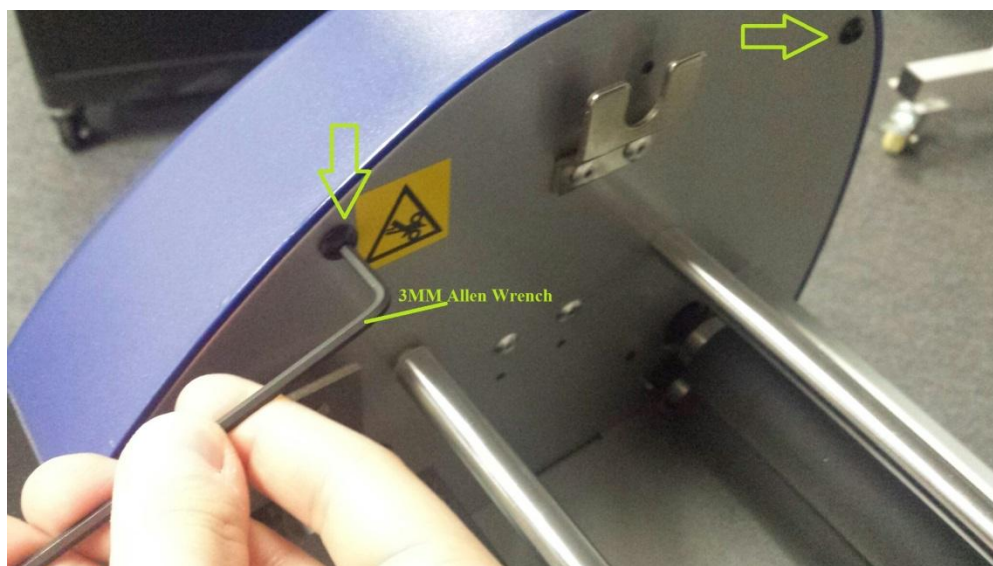

4. Once the cover is removed, locate the Auto Shutoff Timer Board. (see pictures below)

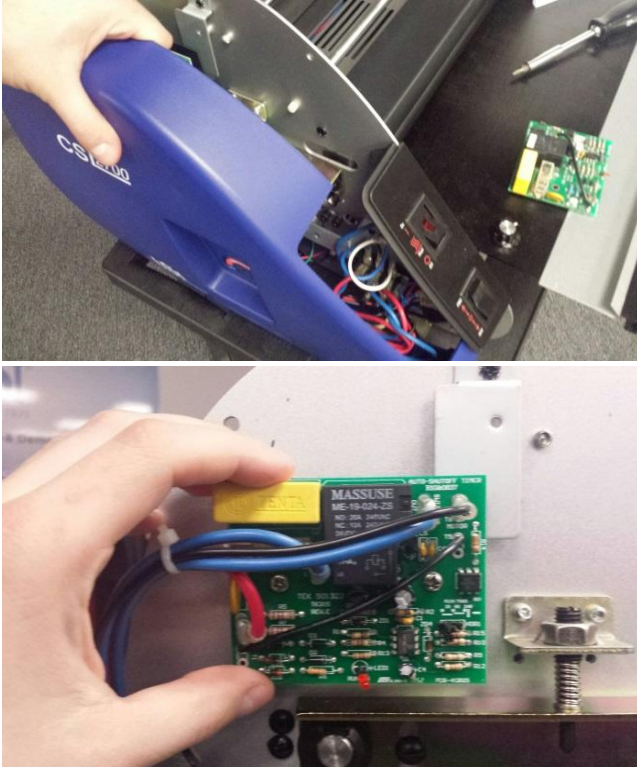

5. Locate your replacement board and move the wires from the old board to the new board **one at a time** – **making sure they are connected to the same connections on the new board** (this is why it is best to do one at a time). (see pictures below)

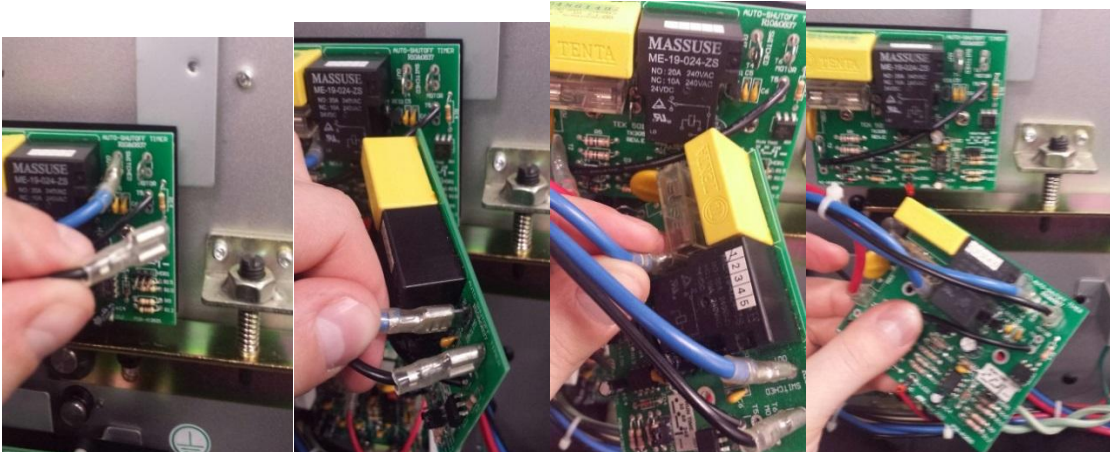

- Once all the wires have been moved to the new board, Unscrew the old board from the mounting plate, and fasten the new board in its place using the old hardware (there are two white plastic spacers and a black plastic insulating plate in addition to the two screws). (See pictures below)

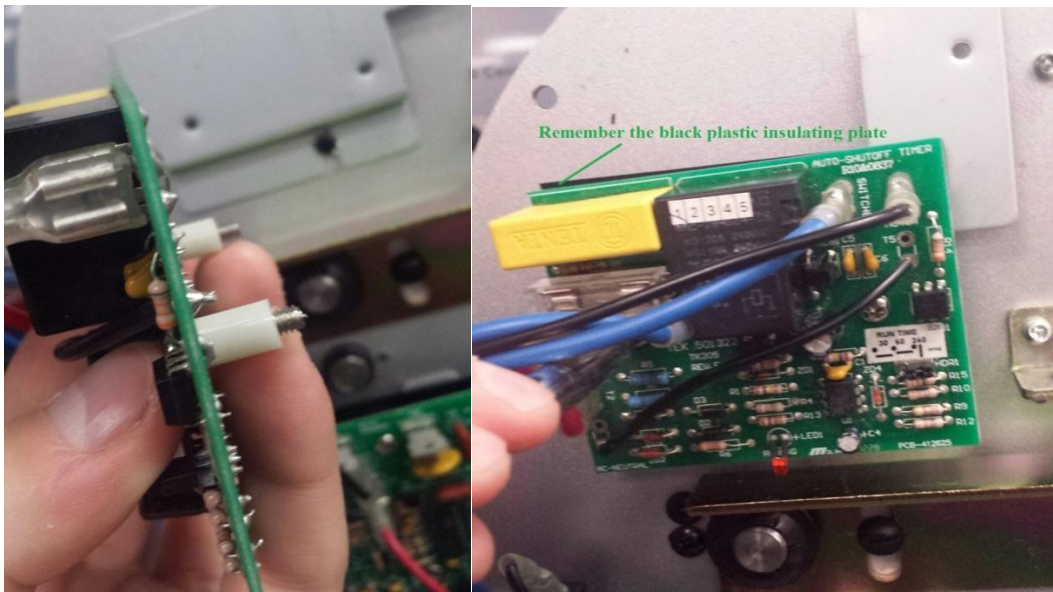
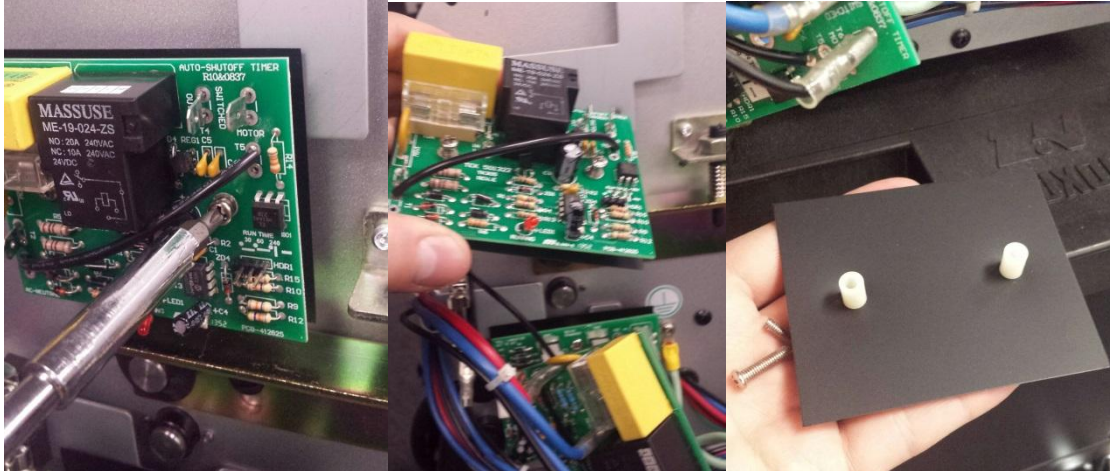

- Your new Auto Shutoff Timer Board is now installed.

Final instructions on the next page:

8. You can also select the “Run Time” on your Auto Shutoff timer. By default it may be set to 1 hour or 30 minutes – new machines are generally set to 4 hours – so this may be preferable (replacement boards for shipping purposes are usually sent with the jumper connecting 2 pins so it does not fall off in the package this means it is set to either 30 or 60 minutes). To set your timer for 4 hours you can hang the jumper by any of the 3 pins as shown in the pictures below.

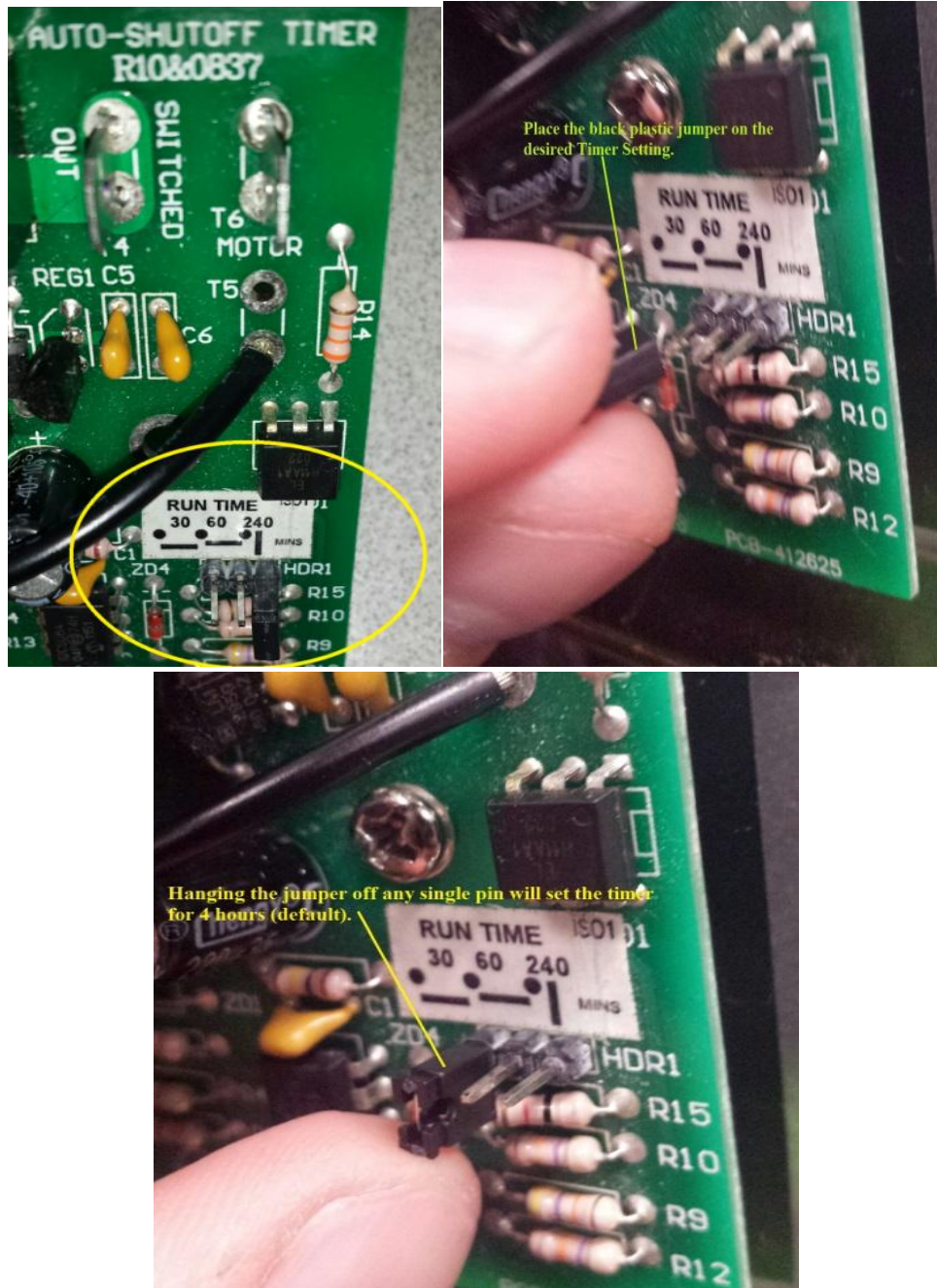

9. \*\*\*\*You may at your discretion choose to **TEST THE MACHINE** before reinstalling the plastic side cover.
10. If you chose to **test the machine** before reinstalling the cover **BE CAUTIOUS OF DELICATE/DANGEROUS ELECTRICAL CONNECTORS** until the cover is reinstalled.

If you have questions or need more information, please contact  
USI's best-in-class  
Customer Service and Technical Support Team!

Visit [www.usi-laminate.com](http://www.usi-laminate.com)

Call 1-800-282-9290

Email [customers@usi-corp.com](mailto:customers@usi-corp.com)