

READ ALL PRECAUTIONS & INSTRUCTIONS CAREFULLY
BEFORE OPERATING LAMINATOR

Setup

Instruction

Operation

Lamination

Maintenance

Educator Laminator

Operation Manual

IMPORTANT: Don't laminate one-of-a-kind documents unless you are sure of your laminating skills and can afford to damage or ruin the document.

Don't laminate valuable items such as stamps, baseball cards, autographs or other collectibles because the value of such items can be destroyed by lamination. Collectors generally value these kinds of items only in their original state.

Remember that you cannot laminate thermal paper, such as typical fax paper, because it is activated by heat and will turn black. Also, remove paper clips and staples because they can damage the rubber rollers. Be careful about laminating anything that will be affected by heat. For example, the colors in crayon drawings may run together or be smeared, especially if the crayon layer is heavy. Light crayon drawings may not be affected, but test an expendable sample of any item that may not laminate well.

IMPORTANT: Éviter de plastifier du papier thermosensible, comme le papier de télécopieur, puisqu'il noircira sous l'effet de la chaleur, et enlever les trombones et les agrafes qui risquent d'endommager les rouleaux de caoutchouc. Prendre certaines précautions avant de plastifier des articles susceptibles de réagir à la chaleur comme les dessins au pastel dont les couleurs baver et se mélanger, surtout si la couche de pastel est épaisse. Les pastels en couche mince peuvent ne pas réagir, mais, en cas de doute, il est préférable de faire un essai avec un échantillon perdu.

Ne pas plastifier les documents importants dont il n'existe qu'un seul exemplaire, à moins de bien maîtriser la technique de plastification.

Ne pas plastifier non plus les articles de collection comme les timbres, les cartes de baseball, les autographes ou autres, qui peuvent perdre leur valeur pour les collectionneurs s'ils ne sont plus dans leur état d'origine.

IMPORTANTE: Recuerde que no puede laminar papel térmico, tal como el papel de fax típico, ya que es activado por el calor y se tomará negro. Retire también cualquier sujeta-papeles o grapa, puesto que pueden danar los rodillos de goma. Evite laminar cosas sensibles al calor, por ejemplo, los colores de dibujos hechos en lápiz de pastel pueden no ser afectados, pero ensaye con alguna muestra descartable, en los ítemes que podrían no laminarse bien.

No lamine ningún documento único, a no ser que esté muy seguro de sus habilidades de laminador y pueda permitirse arruinar el documento.

No lamine artículos de valor, como estampillas, tarjetas de béisbol, autógrafos, u otros coleccionables, ya que su valor puede ser destruido por la laminación. En general, las coleccionistas valoran este tipo de artículo en su estado original.

TABLE OF CONTENTS

1-1 INTRODUCTION

- 1-2 Features and benefits
- 1-3 Options
- 1-4 Characteristics
- 1-5 Principles of operation
- 1-6 Laminating film
- 1-7 Warranty

2-1 UNPACKING AND INVENTORY

3-1 PRODUCT ILLUSTRATIONS & NAMES OF PARTS

4-1 SAFETY PRECAUTIONS

5-1 SETUP & OPERATION

- 5-2 Threading the laminator
- 5-3 Threading diagram
- 5-4 Laminating
- 5-5 Recommended temperature settings
- 5-6 Preventing and solving problems

6-1 INSTRUCTIONS FOR OPTIONS

- 6-2 Footage counter
- 6-3 Slitters

7-1 MAINTENANCE

- 7-2 Cleaning the heat shoes
- 7-3 Cleaning the rubber rollers
- 7-4 Lubrication

1-1 INTRODUCTION

This laminator is designed to provide quality lamination of a wide range of papers and materials up to 1/8-inch thick using film up to five mil thick. Common applications include but are not limited to maps, digital imaging, packaging, posters, instructional aids, signs, presentation materials, photographs, copies (B&W or color), prints, flyers, promotional sheets and many other items. Options include a footage counter, and a roll feed.

To assure the best performance from your new laminator, please follow the safety, installation, operation, and maintenance instructions in this manual. Read the manual before using the laminator, keep the manual with the machine, and periodically review the instructions. The manual also contains warranty and parts information.

The International "HOT" warning symbol will be placed on the appropriate areas of each laminator.

Le symbole international de mise en garde "CHALEUR EXTREME" sera apposé aux endroits appropriés des machines à plastifier thermiques.

El símbolo internacional de advertencia "CALIENTE" será fijado en los lugares apropiados, en el plastificador.

We take this opportunity to thank you for selecting the laminator and to assure you of our commitment to your satisfaction with our products.

As you unpack your new laminator, please complete the following information. Always have this information ready when calling.

Dealer where purchased _____

Installation Date _____ Serial # _____ (back of the laminator)

- **WARNING:** High temperatures are present and care should be exercised in operating the laminator. The laminator should not be operated without the plexiglass safety shield.
- **MISE EN GARDE:** *La machine à plastifier produit beaucoup de chaleur et on doit l'utiliser avec prudence. Ne pas utiliser la machine à plastifier sans son écran protecteur en plexiglass*
- **ADVERTENCIA:** *El plastificador produce temperaturas muy altas; tenga cuidado al utilizarlo. No utilice el plastificado sin tener el protector de plexiglass en su lugar.*

Ledco, Inc.
4265 North Main Street
Hemlock, NY 14466
Web: ledcoinc.com

Fax 585-367-2978
Phone 585-367-2392
Email: ledco@ledcoinc.com

1-2 FEATURES & BENEFITS

Your new laminator has several standard features that set it apart from other models.

- **The clear safety shield** keeps fingers away from heat shoes and laminating rollers while allowing you to see your work.
- The easily accessible **heat control** permits the use of many different types of thermal laminating film from 1.5 to five mil thick.
- **Ease of cleaning** The silicone rubber rollers and the teflon-coated heat shoes of the laminator should be cleaned regularly.
- **Tension control knobs** are built into both supply roll mandrels so that wrinkles and curling in the film can be eliminated.
- **Ease of maintenance** The Educator is made to last, however, some items on a laminator do wear out. Even the high-quality silicone rubber used in the rollers will lose flexibility over time. Extensive use may wear out the rollers or an operator may cut a roller by accident. Rollers and other key parts can be changed quickly without disassembling the frame.
- **Reverse** can be invaluable at times to help avoid problems or clear misfeeds.
- **Silicone rubber laminating rollers** are flexible enough to provide a good edge seal and firm enough to offer a good surface seal. A high silicone content insures a much longer average roller life. They can accommodate poster board or other materials up to 1/8" thick.
- **Very strong steel cores** prevent roller flexing and insure uniform pressure across the width of the laminate, giving you the best quality lamination available in a medium-duty commercial machine.
- **Zippy safety cutter** is shipped with the laminator to allow quick and easy cutting and trimming of the lamination web.
- **Removable power cord** prevents unauthorized usage without locking away the whole machine.
- **100% Made in the U.S.A**

1-3 OPTIONS

There are several options available to make the Educator more versatile.

- **Footage counter** This device can be reset to measure film usage in feet. Also available in a metric version. The footage counter and slitters will not fit on the machine together.
- **Slitters** can automatically cut away side scrap which can greatly reduce the amount of time needed to trim your work. Most Educator-class laminators do not have slitters available. The slitter knives can be completely retracted into their holders when not in use.
- **Right side feed guide** to go with the standard left side guide and feed one sheet at a time with greater accuracy or feed two sheets at a time in alignment with each other.
- The **dust cover** will help keep the machine clean while not in use.

1-4 SPECIFICATIONS

Laminating Width	up to 25"
Speed	5 FPM
Maximum film roll diameter	6"
Maximum film gauge	5 mil
Maximum laminating thickness	1/8"
Dimensions	32L 11H 16W
Shipping dimensions	37L 17H 18W
Weight / shipping weight	76/84 lb.
Electrical	110V (220 optional) 1560 watts 15 amps

* specifications are subject to change without notice

1-5 PRINCIPLES OF OPERATION

The laminator operates by pulling film with a thermally activated adhesive over a heat source and into a set of laminating rollers. Film from a supply roll passes over heat shoes to activate a polyethylene adhesive layer on the film. It then passes through rubber rollers to apply pressure and bond the film to the item being laminated. The film's adhesive is pressed into the ink and fibers on the surface of the paper.

The strength of the lamination bond can be checked by cutting a large "X" on the surface of a laminated sample with a sharp blade. Use the tip of the blade to pry up one corner of the "X". Grab that corner and pull up the film. Ink and/or paper fibers coming up with the layer of film indicates a good adhesive bond.

If the film comes up too easily, with no ink or paper, the lamination was probably done at too low a temperature. Check the instructions that may have come with your laminating film and/or the lamination temperature chart in section 5-5.

Please note that when doing an X-test on glossy (coated) paper, a good X-test will pull up ink only. The film should not come up easily. When laminating material that is not glossy (uncoated), the paper is often more fibrous and a good X-test will yield ink and paper fibers coming up with the film.

1-6 LAMINATING FILM

Most thermal laminating film consists of two layers: a base of polyester and an adhesive layer of polyethylene. The polyester layer forms the harder outer surface of the film and does not melt at laminating temperature. It provides rigidity and protection for your laminated items. The greater the polyester content, the higher the level of protection, rigidity and luster. The polyethylene layer melts at laminating temperature and bonds the film onto the subject material under the pressure of the laminating rollers. As an X-test demonstrates, the adhesive is pressed into the paper and fills irregularities in the surface.

The proportion of polyester and polyethylene in a film is usually described with numbers. For example, a "1-2" film consists of one mil of polyester and two mils of polyethylene. The first number refers to the base layer. The second number refers to the adhesive layer. A mil is 1/1000 of an inch.

Since polyester is the more costly of the two types of plastic generally used in laminating film, a "3-2" film will cost more than a "2-3" film. Both are 5-mil films but the "3-2" version will seem a little thicker on a piece of laminated material because it will be slightly stiffer. Thermal laminating films are available in many different base/adhesive combinations. Five-mil film, for example, can be found in 1-4, 2-3, 3-2 and 4-1 combinations.

In the US laminating trade, the generally accepted practice is to describe two-sided lamination, or encapsulation, by the thickness of one layer of film. For example, "3-mil lamination" should refer to lamination with two layers of 3-mil film. If you are buying or selling laminating film or lamination services, please make sure both parties understand the film descriptions being used.

There is a huge variety of thermal laminating films available to suit many different kinds of application. Here are some of the more commonly used "special" film types or film additives:

- film with low-melt adhesives, also known as co-polymer films; these often have better clarity and are less likely to curl or ripple
- matte films to eliminate glare or to accept printing or writing; many suppliers offer films with both glossy and matte (non-glare) finishes

Rolls of film may be purchased in different widths. The size of the laminator is the only limitation to the width of the film rolls you can use. The Educator can use 4, 12, 18, or 25 inch rolls. Make sure the upper and lower roll widths are the same, and are aligned with each other.

Rolls are also produced with different lengths of film on a roll (250', 500', 1000'). The Educator will easily accommodate film rolls up to a 6" diameter.

When installing film, always center the rolls of film on the supply roll mandrels so the core grippers engage the cardboard core. Look for the score marks around the supply roll mandrels to aid in aligning the top and bottom rolls.

We recommend 3-mil film for most common applications, including posters, signs or instructional aids. The 3-mil film provides better protection, more rigidity, and a more lustrous appearance than 1.5-mil film. Five mil film is suggested for those applications that need the most protection and rigidity.

Lamination with 1.5-mil film can sometimes present problems because the film is so thin it loses heat easily. It sounds backwards, but 1.5-mil film has to be run at a higher temperature than a 3-mil film with the same adhesive. The higher temperature compensates for the faster rate of heat loss during lamination. A standard 3-mil film is applied at 280° F, while a standard 1.5-mil film must be applied at 310° F. Even when applied at 310° F, a 1.5-mil film is still more likely to delaminate later.

If the item being laminated is fairly thick, it will pull heat from the film. This will lower the temperature of the 1.5-mil film and prevent it from sticking properly. When laminating thick items with standard 1.5-mil film, it may be necessary to raise the temperature to 330° F or 340° F. Do not use any higher temperature for any film than is needed to get an acceptable degree of adhesion, as measured by an X-test. Remember there are low-temperature films that should run at much lower temperatures than those cited in this example. (see the chart on film operating temperatures.)

Rolls of film are sometimes spliced. Most film suppliers will mark a splice with colored tape. This way, you can see the splice as a "dash" of color on either end of the roll. If you spot a spliced roll in advance, you can put it on the top supply roll mandrel in order to see the splice coming more easily and avoid putting material under the splice. Or you could put it on the bottom roll if you plan to be laminating items that will never be seen from the back side.

1-7 WARRANTY

This laminator is guaranteed against defects in material and workmanship for a period of **two year** after date of shipment. Defective parts will be replaced without cost within the warranty period, provided the laminator has not been abused, altered or operated contrary to instructions. Ledco, Inc. shall not be liable for any alternations or repairs except those made with its written consent.

This obligation under warranty shall not extend to the following:

- The adjustment or replacement of parts which are the normal responsibility of the owner. For example, rubber rollers, heat shoe coatings, scratched or chipped paint, loose fasteners (screws, nuts, etc.), or other items that show wear under normal use; i.e. "normal wear parts."
- Normal operating adjustments to heat, speed, tension, etc.
- Parts that are not manufactured by Ledco, Inc. If the individual manufacturer warrants these items, their warranty is, in turn, passed on to the original purchaser of the laminator. Ledco, Inc. does not incur any obligation or liability as a result of the warranties that are the sole responsibility of the appropriate individual manufacturer.

Any laminator that proves defective during the warranty period may be returned to Ledco, Inc. unless it is decided that the necessary repairs can be made during a service call. Notice of the defect should be submitted in writing or by phone to Ledco before any steps are taken to repair or return the machine. Phone: 585-367-2392 Fax: 585-367-2978

If the machine is returned, the following should accompany it.

- Customer name, address and phone number
- Written particulars regarding the malfunction
- Date of installation
- Serial number of the machine.
- **All returns must have a return authorization number on the outside of the shipping container.** Send all returned equipment freight PREPAID to:
Ledco, Inc., 4265 North Main Street, Hemlock, NY 14466:
Tel: 585-367-2392 • Fax: 585-367-2978 • email: ledco@ledcoinc.com

If your machine needs servicing after the warranty has expired, please contact your dealer. Ledco, Inc. does offer technical support if your dealer is unable to assist.

This warranty is expressly in lieu of all other warranties expressed or implied, including the warranties of Merchantability and Fitness For Use and of all other obligation or liabilities of Ledco, Inc.. Said company neither assumes nor authorizes any other person to assume it for any other obligation or liability in connection with the sale of this laminator except as provided for above.

Further, this warranty will not apply to any machine or part thereof which has been damaged as a result of an accident or as a result of the abuse, misuse, or neglect of the machine. The warranty is also void if the laminator has been altered or repaired by any other than an authorized repair facility or dealer.

2-1 UNPACKING AND INVENTORY

WHILE UNPACKING YOUR MACHINE: Be sure to lift using the handles on both ends of the machine carefully and evenly as possible to avoid breaking off the heat control knob.

Except for the supply roll mandrels and feed tray the laminator is assembled at the factory. Upon arrival, inspect the unit immediately and thoroughly using the packing list that accompanies the shipment. Please follow these steps to correct any problem with your shipment. Ledco, Inc. cannot accept any responsibility for damage or loss unless you notify us within ten days of receipt of shipment and follow these procedures:

BREAKAGE OR DAMAGE: It is imperative that any shipping damage is reported and a claim is filed with the delivering carrier immediately upon receipt of damaged shipment. The procedure for reporting damage depends on the method of shipment. Please note damage on bill of lading.

FREIGHT, EXPRESS, or TRUCK DELIVERY: According to the contract terms and conditions of the carrier, the responsibility of the shipper ends at the time and place of shipment. The carrier then assumes full responsibility for the shipment.

1. Notify Ledco **IMMEDIATELY**.
2. Hold damaged goods with container and packing for inspection by the examining agent. Ledco will arrange the inspection.
3. **DO NOT RETURN ANY GOODS TO LEDCO PRIOR TO AUTHORIZATION BY LEDCO.**
4. Submit a copy of the inspector's report to Ledco. Ledco will file the claim with the carrier. Ledco will replace your machinery if necessary. You will be credited for the damaged machinery when the claim is processed.

SHORTAGE:

1. Check the packing list notations. The apparent shortage may have been marked as an intentional short-shipped (back-ordered) item.
2. Re-inspect the container and packing material, particularly for smaller items.
3. Make certain that unauthorized personnel prior to complete unpacking did not remove the item and inventory.
4. Call us and send immediate written notification of the shortage.

INCORRECT SHIPMENT:

1. If the material you receive does not correspond with your order, notify Ledco immediately. Include the order number and item(s).
2. Hold item(s) until return instructions are received.

RETURNS: DO NOT RETURN DAMAGED OR INCORRECT ITEMS UNTIL YOU HAVE RECEIVED SHIPPING INSTRUCTIONS AND AN AUTHORIZATION NUMBER FROM LEDCO.

3-1 PRODUCT ILLUSTRATIONS & NAMES OF PARTS

The photos below and on the following pages identify major components and operating controls. Refer to them as you study the installation, operating and maintenance procedures described in this manual.

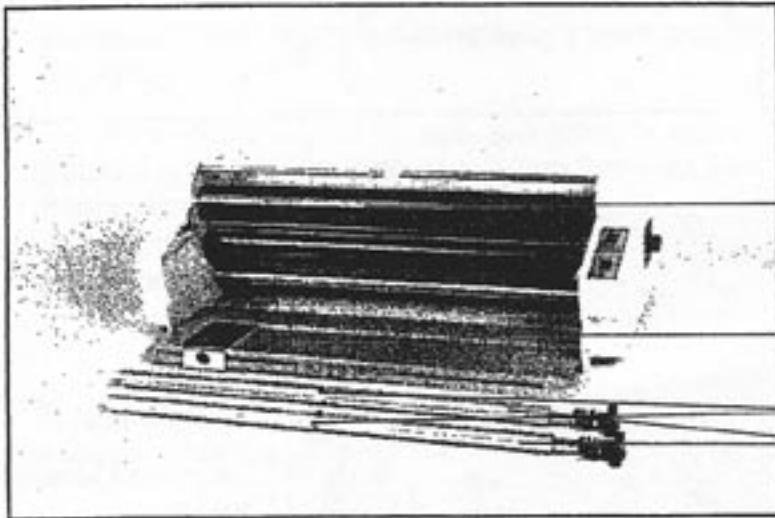

- Safety Shield
- Feed Tray
- Core Grippers
- Supply Roll Mandrels

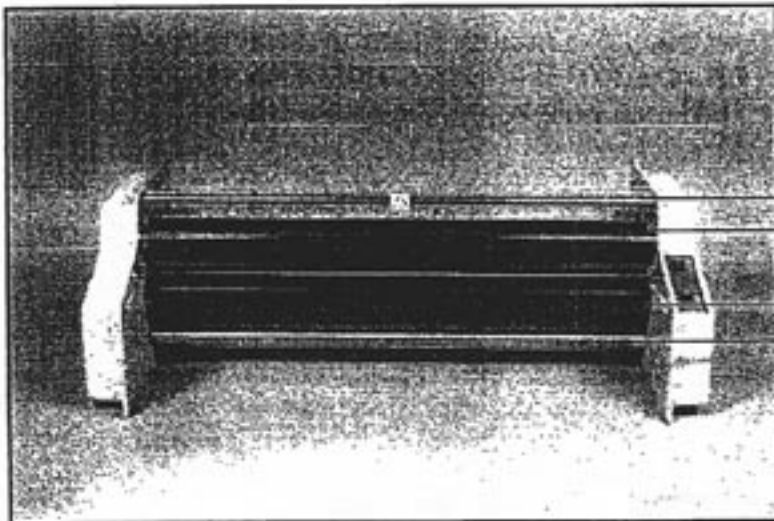

- Upper Stabilizer Bar
- Upper Heat Shoe
- Lower Heat Shoe
- Bottom Idler Bar

Accessory Mounting Holes
 Laminating Rollers
 Wrap Around Guard

*Pull Rollers are located
 beneath wrap around guard.

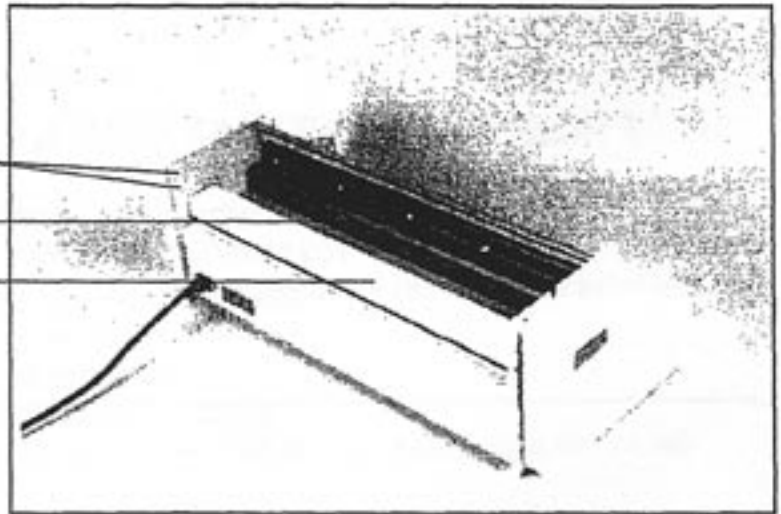

Feed Guide
 Feed Tray

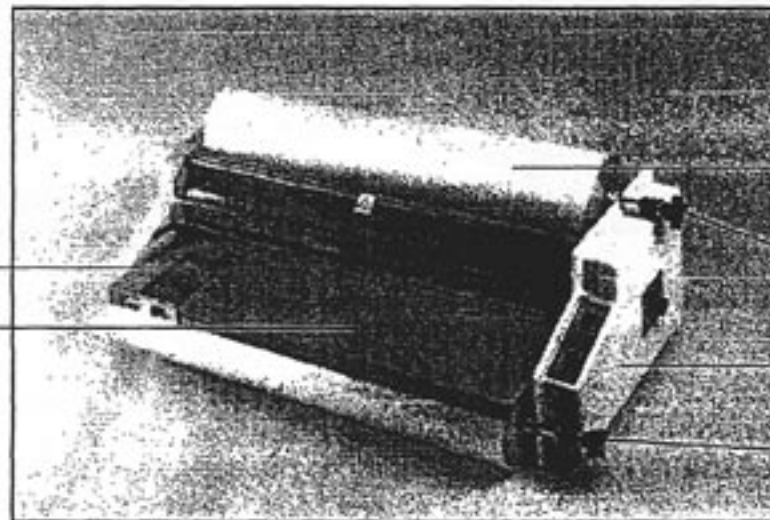

Top Film
 Supply Roll
 Tension Control
 Knob
 Right Housing
 Bottom Film
 Supply Roll

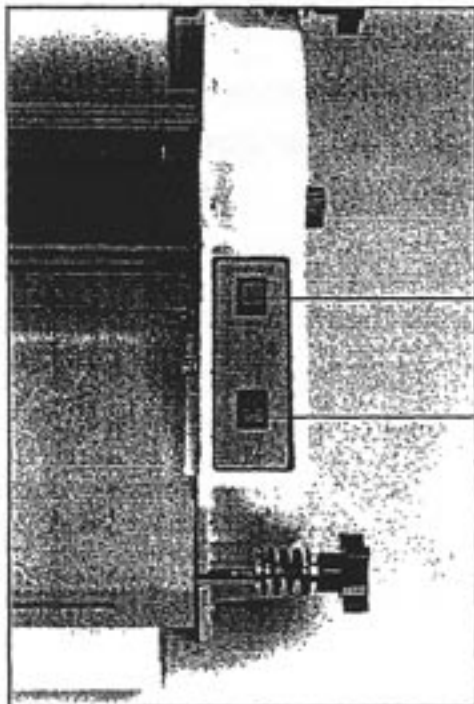

Drive Switch
 Heat / Power Switch

4-1 SAFETY PRECAUTIONS:

DANGER

1. High temperatures are present and care should be exercised in operating and maintaining the laminator. Even after the machine has been turned off it will remain hot for an extended period of time. Contact with hot surfaces may cause burns.

MISE EN GARDE! Etant donné les températures élevées produites par cette machine à plastifier, on doit user de prudence lors de son utilisation et de son entretien. Même une fois l'alimentation électrique coupée, la machine demeure chaude longtemps. Éviter tout contact avec les surfaces chaudes, qui peuvent causer des brûlures.

PELIGRO! Hay temperaturas altas aquí y debe tenerse cuidado durante la operación y el mantenimiento del plastificador. Aún después de haber sido desconectado, el plastificador permanecerá caliente durante un período prolongado. El contacto con las superficies calientes puede causar quemaduras.

2. Always make sure the power cord is not placed under the laminator where it might get overheated from proximity to the bottom heat shoe.

On doit éviter que le cordon d'alimentation ne passe sous la machine et soit exposé à la chaleur élevée produite par le sabot chauffant inférieur.

Asegúrese que el cordón eléctrico nunca esté debajo del plastificador, donde podría ser recalentado debido a la proximidad de la zapata calefactora inferior.

DANGER

3. The safety shield must remain attached to the machine and in position any time there is power to the machine. You may tip the safety shield down while loading the film. Always make sure the rollers are NOT turning when the safety shield is flipped down.

MISE EN GARDE! L'écran de sécurité doit être monté sur la machine en tout temps quand elle est sous tension. On peut relever l'écran pour charger la pellicule. Toujours s'assurer que les rouleaux ne tournent PAS avant de relever l'écran.

PELIGRO! La pantalla protectora debe quedar fija a la máquina y puesta de manera que la máquina siempre reciba energía. Puede levantar la pantalla protectora mientras carga la película. Asegúrese de que los rodillos NO estén funcionando cuando se saca la pantalla protectora.

DANGER

4. Never operate the laminator with neckties, jewelry, or loose clothing. Tie back long hair. These items can be caught and be pulled in by the laminator causing serious injury.

MISE EN GARDE! Attacher les cheveux longs et ne jamais porter de cravate, de bijoux ou de vêtements amples quand on utilise la machine à plastifier, qui risquent de les entraîner et de causer ainsi des blessures graves.

PELIGRO! Nunca opere el laminador usando corbatas, joyas o ropa holgada. Amárrese el pelo largo. Estos objetos se pueden enredar en el laminador y causar un daño serio.

5-1 SETUP & OPERATION

With the laminator on an unobstructed, level surface, perform the following checkout before threading the machine with film.

WARNING: Make sure the power cord is clear of the underside of the machine prior to operation to avoid overheating the cord.

MISE EN GARDE: S'assurer que le cordon d'alimentation ne passe pas sous la machine, ce qui l'exposerait à la chaleur élevée produite par le sabot inférieur.

ADVERTENCIA: Antes de operar la máquina, asegúrese que el cordón eléctrico no está debajo de la misma, para evitar el recalentamiento del cordón.

1. Remove all packing straps, rubber bands, tape, and plastic ties from the machine. Remove the protective paper from the safety shield.
2. Turn the heat/power switch to the Off position. Move the drive switch to the middle/Off position.
3. Plug the machine into a working outlet of at least 15 amps. Plugging in the machine does not power on any control unless a switch has been left on.
4. Turn the heat/power switch to the ON position. The heat indicator lamp in the heat switch will come on. It will stay on until the machine has reached set temperature.
5. Once the heat is turned on, it will stay on until the switch is manually turned off. There is no automatic shutoff on this machine, except in the case of a blown fuse.
6. Turn the heat/power switch to the ON position. The heat indicating light will go on.
7. Turn the drive switch to the FORWARD position. The pull rollers and the laminating rollers should rotate. The fans will operate while the drive motor is ON.
8. Turn the drive switch to the OFF position.
9. Turn the heat/power switch to the OFF position, unless you are going to proceed with threading and laminating. Unplug the machine.

5-2 THREADING the LAMINATOR

1. Remove the supply roll mandrels and the feed tray. The supply roll mandrels are now ready to accept loading of the film rolls, wound with the polyester (shiny) side out. When viewed from the front of the machine, the core grippers on both top and bottom supply roll mandrels should point toward the heat shoes (and toward each other). The tension control knobs should be positioned on the right. Notice the knobs are labeled "Top Right" and Bottom Right". If you have rolls of film on which the material is wound in the opposite direction (adhesive or dull side out) exchange the top and bottom supply roll mandrels so the core gripper positions are reversed.

2. Slide a roll of film onto the top supply roll mandrel, turning the roll slightly to slide the gripper inside the core. Center the roll. **Make sure the dull side of the film is facing up and the shiny side is facing the heat shoes during the threading.** Scored marks on the supply roll mandrels provide a guide for proper alignment of the two rolls of film to each other.

NOTE: The pointed metal piece protruding from the center of the supply roll mandrels grips the cardboard core of the film supply roll to prevent slippage. When placing a roll of film on the mandrel, twist the film supply roll in the direction away from the point on the gripper, or the gripper may break or become dislodged from its mounting.

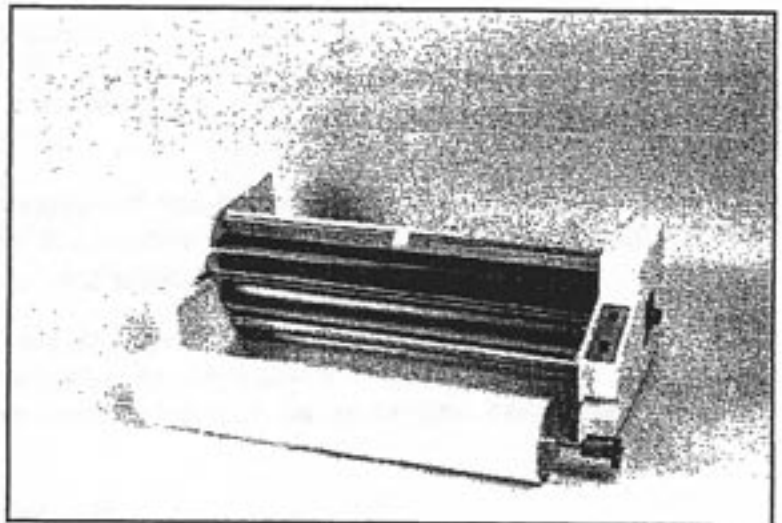
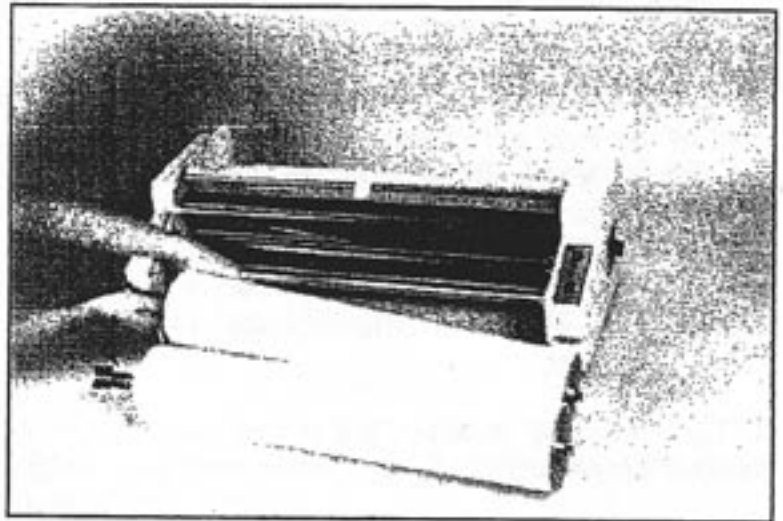
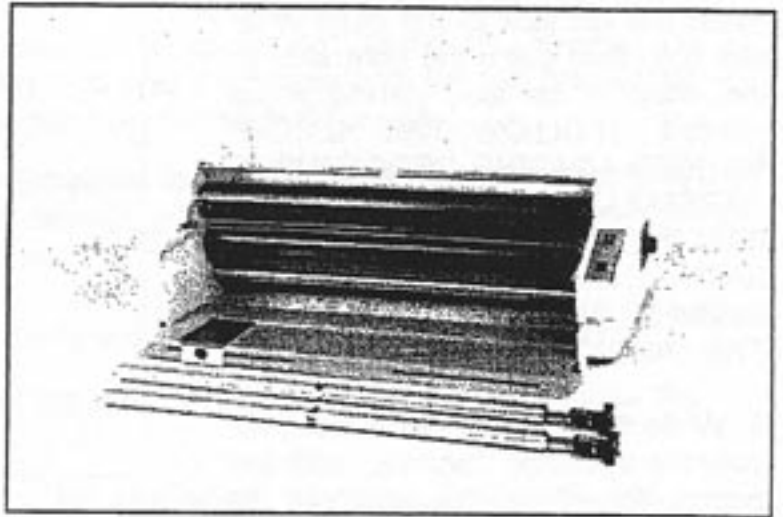

3. With the roll aligned with the scored line on the right side of the mandrel, place it in the top bracket. Place the left side of the shaft in its slot first, then place the right side of the shaft in its slot, turning it as needed. FOLLOW THE RECOMMENDED LOADING PROCEDURES CAREFULLY WHEN THREADING FILM IN THE LAMINATOR. ACCURATE ALIGNMENT OF ROLLS WILL MINIMIZE WASTE AND HELP KEEP THE LAMINATOR CLEAN.

4. While the machine is still cold, review the threading diagram. With the bottom roll of film centered on the mandrel and the shiny side facing down, run the film under the bottom idler bar and pull towards you.

5. Refer to the threading diagram. The top roll of film should run under the silver stabilizer bar and over the front of the top heat shoe. Remember, the shiny side of the film must always go against the shoe. The dull (adhesive) side must face away from the shoe. Make sure the two rolls are aligned with each other before going to the next step.

6. Turn machine on and heat to the desired temperature.

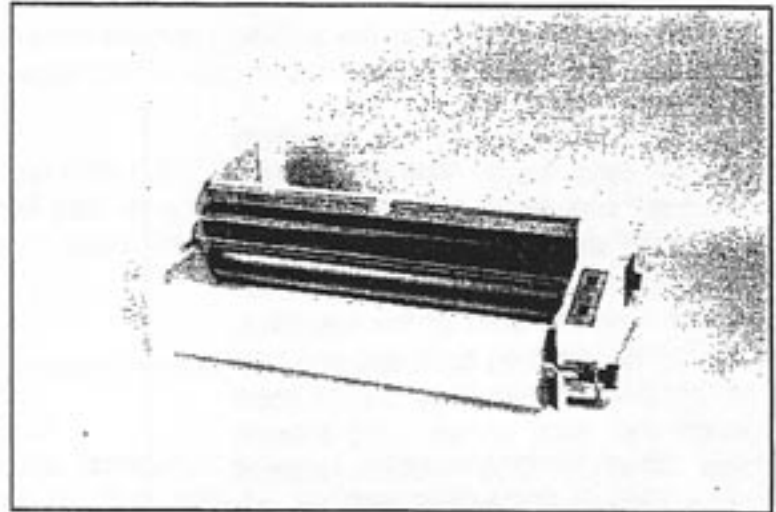

7. With both rolls threaded and installed in their respective brackets, unwind enough film from the top roll to reach the bottom of the bottom heat shoe. Next, unwind enough film from the bottom roll to reach the top of the top heat shoe.

8. Now drape the film from the bottom roll against the film from the top roll on the top shoe. If the laminator is hot, the exposed adhesive on the top web will hold the bottom web and make it easy to stick the two rolls together. If you are threading the machine while it is cold, use tape to stick the bottom web against the top web.

9. Tip the safety shield down into the laminating position. With the film draped over the two heat shoes, push one edge of the threading card between the heat shoes so that the film is firmly positioned against the laminating rollers. If a threading card is not available, any piece of card stock or poster board will work.

10. Make sure there is still enough slack in the web. Turn the drive switch to FORWARD, permitting the film and feed board to pass through both sets of rubber rollers. Carefully monitor initial threading to be sure the web reaches and passes through the pull (back) rollers. When the threading card has cleared the back of the machine, move the drive switch to the center position (off). Whenever you want to remove the film and/or laminated material from the back of the machine, use the Zippy cutting tool provided with the laminator.

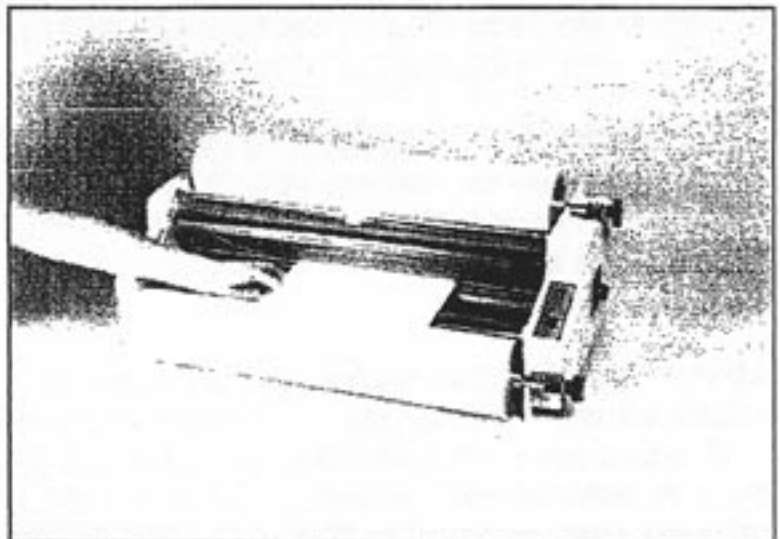
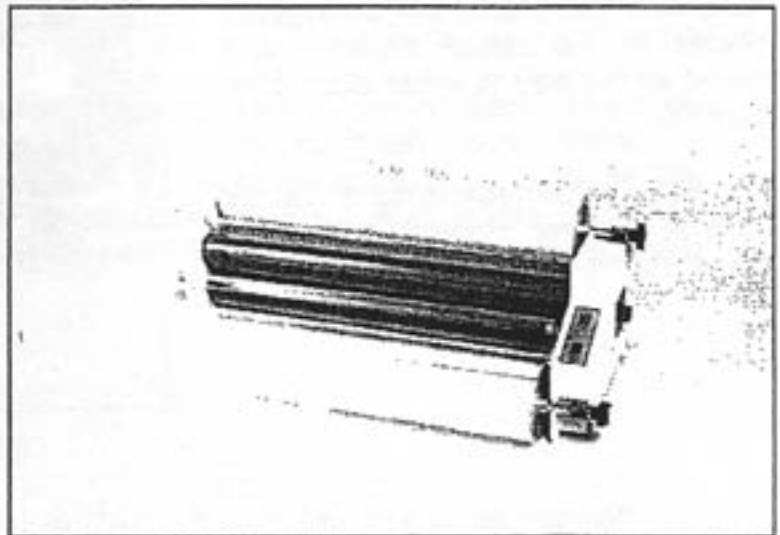

11. Slide the feed tray into position.

12. If the machine has the slitter option, make sure the slitters are disengaged (blades in the raised position) and moved all the way to either side of the machine.

13. Film tension adjustments can be made at this time. Refer to section 5-4 for instruction.

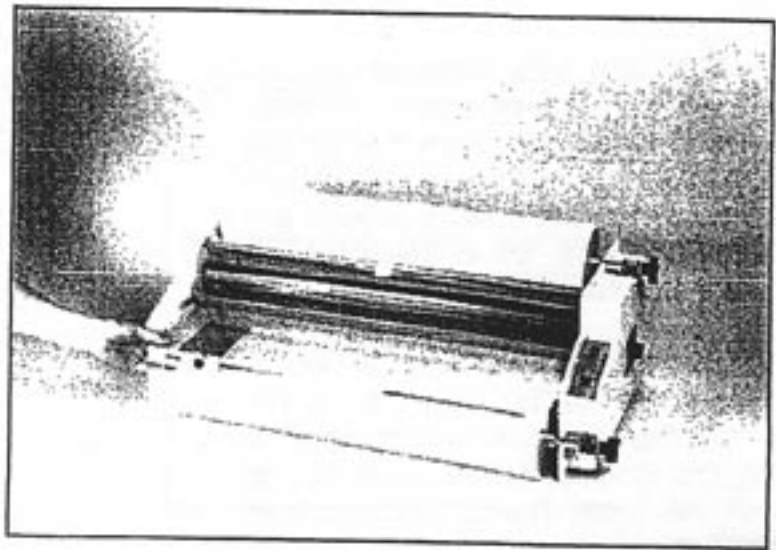

CAUTION: The laminator is designed to be run with the operator directly facing the control panel and feed tray, not at an angle or from the side of the machine. For operator safety, the safety shield must be in position over the upper heat shoe when the machine on ON, or when the drive switch is in the forward position.

AVERTISSEMENT: Le laminoir est conçu pour que l'opérateur soit placé directement en face du panneau de contrôle et du plateau d'alimentation. Pour la sécurité de l'opérateur, l'écran protecteur doit être à sa position désignée lorsque la température des sabots chauffants excède la température normale de la pièce ou lorsque le commutateur est en position marche "AVANT."

ADVERTENCIA: Esta laminadora fue diseñada para que el operador u operadora de la misma trabaje frente al panel de controles y a la plataforma por donde se insertan los artículos que van a ser laminados, y no en ángulo o do lado. Para más seguridad el protector debe de estar siempre colocado sobre los rodillos posteriores cuando el "SWITCH" de la máquina está en posición "ON" o el "DRIVE SWITCH" (switch que impulsa la máquina) en posición "FORWARD".

5-3 FILM THREADING DIAGRAM

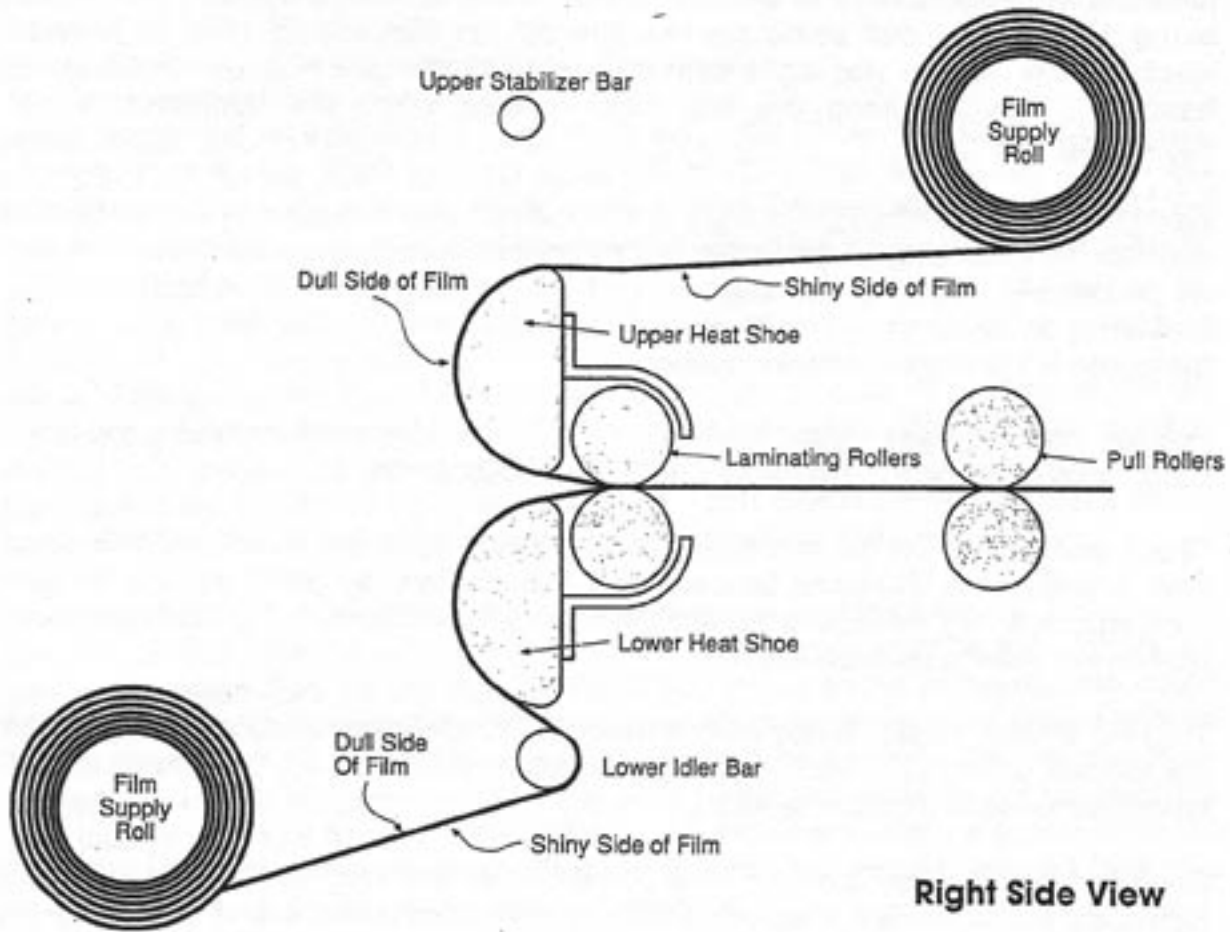

5-4 LAMINATING

1. Turn the heat/power switch to ON. The heater light will come on. The laminator will be ready to operate in about 10 minutes. The heat indicating light will turn off when the machine has reached the correct temperature. Allow about 20 minutes for warm up the first few times the machine is used.

WARNING: Never permit the temperature to exceed 310° Fahrenheit while film is threaded and the laminator is not running. The film could disintegrate and require cleaning and rethreading of the machine. When it is necessary to laminate at temperatures in excess of 310°, such as for poster board or when using 1.5 mil film, pull some excess film off the film supply rolls to provide slack so the film is not tight against the heat shoes while the machine is heating. This will keep the film from melting when the laminator is not advancing film.

When the heat indicating light is on, it means the thermostat is calling for more heat to maintain the laminating temperature. During normal operation, the light will go on and off periodically. After initial warm-up (but not before), there is enough heat for laminating to continue normally even if the light is on. The heat drop during lamination is too slight to affect operation.

2. Position the feed guide for the work to be performed. Adjust by loosening the black knob, sliding the guide to the desired position, and tightening the knob.
3. Check and tension on the film supply rolls to see if the top roll and the bottom roll have approximately the same tension. This may be done by gently rotating the rolls back and forth. If a roll moves too freely it is too loose. If a roll is difficult to move the tension will need to be decreased

Turn the tension control knobs counter-clockwise to decrease tension. These knobs are located on the right ends of the supply roll mandrels. Turn the tension control knobs clockwise to increase tension.

4. Once the machine has come up to temperature, as indicated by the heat indicating light going out for the first time, you are ready to laminate. Check the heat setting dial to make sure the machine is at the right temperature for the film you're using. Making sure that the safety shield is in the operating position (up), move the drive switch to the forward position. Film will begin to pass through the laminating rollers. Once you start the film, watch the film as it passes over the heat shoes to let the wrinkling disappear before inserting material to be laminated. Each time you stop the film, slack will form in the web of film. It will take a few inches to get the slack and the resulting wrinkles past the shoes.
5. Slide items over the feed tray, positioning them against the guide and into the laminating rollers.

6. Examine the film as it exits the machine.

If bubbles or wrinkles appear in the film, this means there is not enough tension to draw the film tight and smooth over the heat shoes. Turn the tension control knobs clockwise to increase the tension.

If the film is tight and smooth as it goes over the heat shoes but then draws in towards the center of the machine or squeals, there may be too much tension on the supply roll mandrels. This can be corrected by turning the tension control knobs counter-clockwise to decrease the tension.

Film that is 1.5-mil thickness requires very little tension.

REMEMBER TO TURN BOTH THE TOP AND BOTTOM TENSION CONTROL KNOBS THE SAME AMOUNT TO KEEP TENSION THE SAME ON TOP AND BOTTOM ROLLS. If the film curls up or down after it leaves the machine, read the above section on supply roll tension again and readjust the supply roll tension on both rolls.

7. When starting the machine to begin lamination, let at least 10 inches of film go through the rollers before inserting the items to be laminated. This takes out slack in the film and removes the cooler strip of film that forms just in front of the nip when the laminator is hot but film is not being advanced. This also removes any areas of film with excess adhesive that may have pooled just beneath the shoes.
8. If the tension appears balanced, but you notice waves or ripples toward the center of the web of film as it comes out the back, the temperature may be too high or the lamination speed may be too high for that film. These waves in the film are called "heat wrinkles". These heat wrinkles are formed when the film has not cooled enough before coming out the back of the machine. For the best results, the film should be cooled below melt temperature while it is pulled tight and perfectly flat between the laminating rollers and the pull rollers. If it gets out the back of the machine while still at or above melt temperature, heat wrinkles can form. The major reason for fans on a laminator is to cool the film, not to cool the machine.

5-5 RECOMMENDED TEMPERATURE SETTINGS

The recommended temperature setting for low-temperature 1.5-mil film is 240° F. If you are laminating with a different thickness of film, refer to the following table for recommended temperature settings.

Your first source of information about recommended film application temperatures and operating characteristics should be your film suppliers. If you do not know the source of your film, or if the supplier cannot provide the information, please use the following table as a guide.

FILM MELT TEMPERATURE CHART (ALL FAHRENHEIT)

FILM TYPE	FILM THICKNESS		
	1.5-1.8-mil	3 mil	5 mil
Monopolymer	310°-320°	280°-290°	270°-280°
Low-temp (copolymer)	300°-310°	220°-270°	220°-260°
Ultra-low temperature	230°-280°	180°-270°	180°-260°

Several important notes about this chart:

1. Your film vendor must have the primary responsibility for providing information about the film that you are using.
2. This chart is to serve as a general guide when better data is not available.
3. If your film vendor cannot provide this and other information about the film you are using, it may be difficult to achieve good results.
4. When laminating heavy posters or other thick items with 1.5 to 1.8 mil films, some additional heat may be required to get a permanent bond. Never exceed 340° F.
5. While offset printed materials may be laminated at the lower ends of the above ranges, inkjet and other output from digital printers may require the upper end of the range in order to get a good bond.
6. See 1-6 LAMINATING FILM for more information.

NOTE: It is possible that variances from recommended temperature settings may be necessary due to material thickness, ambient temperature, humidity or the quality or thickness of the material being laminated.

Please note the wide range of temperatures listed, especially for heavier films. This does not mean any film that thick can be run anywhere within the given range. There are "standard" or high-temperature and "low-melt" or low-temperature versions of all film thickness. Some low-melt films work at lower temperatures than others do. It is important you buy your film from a vendor who can tell you the following additional information about any film you choose:

- the thickness
- the clarity
- suggested melt-temperature range
- polyester/polyethylene content
- how well the adhesive will stick to the kinds of images you'll be protecting and enhancing

Temperatures may exceed 310° F when laminating poster board or other thick items with 1.5 mil film on a continuous basis. When the machine is stopped, turn the heat off if the setting is in excess of 310° F. **Never set the heat above 350° F with film in the laminator.** Temperatures over 300° F are not needed except with 1.5 mil film. Film that is 3 mil or thicker is generally run at 280° F or less.

5-6 PREVENTING AND SOLVING PROBLEMS

PLEASE READ THIS SECTION BEFORE YOU HAVE A PROBLEM.

PROBLEM: Wrinkling of the material as it goes into the laminating rollers. This problem usually occurs when laminating an item that has been folded, rolled, bent or wrinkled.

SOLUTION: Make sure the leading edge of the item being laminated is laying flat and is inserted parallel to the laminating rollers.

It is sometimes essential to smooth out an item as it passes over the feed table and through the rollers to ensure an even lamination without wrinkles. Smooth from the center of the item, back toward the trailing edges. Once the item starts to feed, you may also pull back and to the sides on the corners of the trailing edge.

If material has been rolled up, take the curl out of it on a table edge before laminating. If some curl remains, it may be helpful to insert the item with the curl down so the leading edge is pressed against the feed tray until just before the nip.

PROBLEM: Wrinkling of the film around the material being laminated.

SOLUTION: This is normal and inevitable on any laminator, especially with thicker material. These wrinkles will be trimmed away with the scrap, so they do not affect appearance. Because the rollers are being held apart by the paper or cardboard, they cannot pull equally on the plastic around the paper. This creates wrinkles that tend to look like the bow waves of a boat, radiating out through the clear part of the web from the sheet of material.

PROBLEM: When two pieces of material are laminated side by side, the plastic adheres to one piece but not the other.

SOLUTION: To get maximum efficiency from the film rolls, you can feed several items into the laminator side by side. However, wrinkling can occur if these items are of unequal thickness, because the laminating rollers are lifted off the thinner items by the thicker items. When laminating items side by side, it is important to arrange them so that the thickness is the same.

PROBLEM: Wrinkling of the plastic on a laminated piece of material.

SOLUTIONS: Make sure you have enough supply roll tension to take the wrinkles out of the film before it gets past the heat shoes (see 5-4 LAMINATING).

Make sure the film is threaded properly (see 5-2 THREADING the LAMINATOR).

PROBLEM: Film gets wrapped around the pull rollers.

SOLUTION: While threading a laminator when the shoes are cold, the loose ends of the unlaminated web are particularly susceptible to "wrap-around" on the rear rollers. To minimize this possibility, pull the threading card after it emerges from the pull rollers until the film clears. Stop the web and trim the film from the back of the unit.

If "wrap-around" does occur while the laminator is cold, you can easily correct it by reversing the direction of the rubber rolls, permitting the laminator to release the film from the rolls.

PROBLEM: Film gets wrapped around the laminating rollers while the machine is hot.

SOLUTION: Leave the heat on so that the adhesive does not harden, and follow the following steps.

WARNING: Be very careful not to touch the heat shoes when the machine is hot.

MISE EN GARDE: *Ne pas toucher les sabots chauffants lorsque la machine est chaude.*

ADVERTENCIA: *No toque las zapatas calefactoras cuando la máquina está caliente.*

1. Remove the feed tray.
2. Cut the film on the top and bottom, just in front of the idler bars.
3. Loosen the film from the heat shoes and grip the two loose ends, holding them together.
4. Press the drive switch down to the reverse jog position allowing the laminator to back out the film that is wrapped around the rolls (the laminator will run in reverse only when the reverse jog is manually engaged) . Firmly pull the film off the roller from the front of the laminator.

WARNING: Keeping the machine in reverse may cause a reverse wrap-around if the film is not getting pulled off the roller. You may need to pull on the film with a lot of force while stopping and starting the drive.

MISE EN GARDE: *Si l'on appuie trop longtemps sur l'interrupteur de marche arrière, le film risque de s'enrouler dans l'autre sens. Appuyer par à-coups sur l'interrupteur et vérifier le résultat chaque fois.*

ADVERTENCIA: *Apretar mucho tiempo el interruptor de marcha atrás puede causar bobinado inverso. Apriételo brevemente, luego suéltelo y observe el resultado. Apriételo nuevamente si se requiere más marcha atrás. Pare si nota que el plástico hala hacia atrás, volviendo sobre los rodillos.*

WARNING: Do not try to cut the plastic off the roller with a knife or other sharp instrument. You will end up cutting the rubber rollers and turn an inconvenience into a major repair bill not covered by warranty.

MISE EN GARGE: *Ne jamais tenter de dégager un film enroulé en le coupant avec une lame tranchante. Vous entaillerez le caoutchouc des rouleaux, ce qui occasionnera des frais majeurs de réparation qui ne sont pas couverts par la garantie.*

ADVERTENCIA: *No intente separar el plástico del rodillo cortando con un cuchillo u otro instrumento filoso. Terminará cortando los rodillos de goma y convertirá una incomodidad en una cuenta de reparaciones mayor, que no esta cubierta por la garantía.*

If this method does not work let the machine fully cool. Remove the heat shoes and cut the wrap-around off the roller with a small pair of scissors, working the point and the cutting edges away from the rubber to avoid damaging the roller. Then clean the rollers per the instructions in the manual.

PROBLEM: Not noticing that the rolls of film are almost used up (one roll of film always runs out before the other.)

WARNING: If the film is run through the laminator without being matched to an opposing film, the adhesive exposed to the rubber rollers will stick to the laminating rollers and create a world-class wraparound. This type of wraparound is difficult to clear because the film adheres to the roller and to itself for the entire length of the accumulated film on the roller. It's best to clear this right away, before the adhesive hardens. Follow the steps above to clear.

MISE EN GARDE: *S'il n'y a qu'un film dans la machine, le coté adhésif, qui se trouvera contre le rouleau de plastification, y adhèrera, ce qui provoquera un enroulement "monstre: très difficile à défaire puisque le film adhère d'abord au rouleau, puis à lui-meme a mesure qu'il s'enroule. Il faut agir rapidement avant que la colle durcisse. Procéder de la facon indiquée ci-dessus pour régler le problème.*

ADVERTENCIA: *Si el plástico de uno de los rollos de abastecimiento pasa por el plastificador sin ser igualado por una película de plástico del rollo opuesto, el adhesivo expuesto a los rodillos de goma adherirá a los rodillos de laminación y causará un bucle monumental. Este tipo de bucle es muy difícil de deshacer porque el plástico adhiere tanto al rodillo como a sí mismo, a lo largo de toda la longitud de la película de plástico acumulada sobre el rodillo. Es mejor deshacerlo inmediatamente, antes de que endurezca el adhesivo. Siga los pasos indicados más arriba para lograrlo.*

SOLUTION: To avoid this problem, stop the laminator before either roll runs out, cut the webs of film, and remove the two near-empty rolls of film and then rethread new rolls. When putting film on a laminator, always use two rolls of matched length and width.

Experienced users may leave the pieces of film remaining over the shoes and in the rollers to help thread the new film. When the machine is warm, the ends of the new rolls can be easily tacked to the already threaded pieces because the adhesive layer facing outwards will be sticky. Be careful not to burn yourself on the heat shoes.

PROBLEM: Film is not properly adhered or starts to come off sometime after lamination.

SOLUTION: Unless there is something wrong with the film, this problem comes from film being run at too low a temperature. Check the heat setting on the laminator. If the film is not sticking to the item, it is likely that more heat is required.

Keep in mind that not all items (printed, photo copied, ink jet, fax copies, photographs etc.) are lamination friendly. Certain combinations of inks, papers, receiving layers on papers (such as glossy photo papers) , crayon, oil paints, pastels , etc can sometimes prove to be a challenge for laminating films to adhere to. When in doubt, it is best to run a sample piece(s) as close in make up to the item to be laminated as possible to check for adequate adhesion.

When laminating posters or other thicker material with 1.5 mil film, the paper itself can absorb enough of the heat from the film to drop the adhesive below its melt temperature. The film may start to come off immediately or it may start to fall off after a few days. The solution here is to run the work at a higher temperature. About 320° to 340 °F will usually do the job.

Sometimes you may see film detach from an item along one edge (the edge that was put in first). This happens when the material is put all the way into the nip before the machine is started. The area of film between the shoes and the nip can cool off too much while the machine is idle. The adhesive may not be hot enough to stick.

The way to prevent this is to let a few inches of film go though before putting in sheets to be laminated. This serves other purposes, besides ensuring the front edge of the piece will be properly sealed. It gives the machine a chance to take up the slack that develops in the film whenever the machine is stopped, and it prevents the following problem as well:

PROBLEM: A laminated item comes out with a large "oily" spot on or near the leading edge.

SOLUTION: It's not oil that causes this effect, but excess adhesive. When a machine is heated but allowed to idle for a few minutes or longer, the adhesive from the film over the shoes can form droplets if material is put in immediately. This excess adhesive saturates an area of paper, creating what looks like an oily spot. The solution, as mentioned above, is just to let a few inches of film go through before feeding in your work.

Anytime you are laminating unfamiliar or costly items; it is a good idea to start with an expendable sample or test piece. Laminating a test piece first gives you an indication of the results you'll get and also takes care of any pooled adhesive.

PROBLEM: A milky, hazy line about an inch wide appears periodically across the width of the web immediately after initial warm-up.

SOLUTION: The rollers are not evenly heated, and the cold side of the rollers is preventing the adhesive from melting. When warming up the machine, keep the rollers open and keep the forward drive on at low speed.

PROBLEM: The machine produces a continuous squealing noise when laminating.

SOLUTION: To a certain extent, it is normal for some laminating film to squeal as it is pulled over the heat shoes under tension. This noise is produced via the same principles that make a violin squeal. Some of the compounds put on film to keep it from sticking to itself seem to act like resin on the bow of the violin —they enhance the noise.

To minimize squealing, run the laminator with the least amount of supply roll tension that will do the job of removing wrinkles from the web of film. Make sure you are not using a higher temperature than needed and clean the heat shoes periodically. If the noise gets really objectionable, use a different type or different brand of film.

PROBLEM: The laminated material seems to have a pitted surface or irregular surface that does not match the texture of the paper being coated.

SOLUTION: This is usually caused by adhesive build-up or dirt on the rubber rollers, but may be caused by any matter stuck to the rollers, such as a piece of paper. Inspect the rubber rollers and if they need cleaning refer to the owner's manual.

Cuts or other damage to the rubber rollers, especially the laminating rollers, can also cause irregularities in the surface of the film. The pull rollers are identical to the laminating rollers and could be substituted if still in good condition.

PROBLEM: The film shrinks as it passed over the heat shoe (known as "necking in the laminating trade).

SOLUTION: Reduce the heat and/or the supply roll tension. The film is not shrinking so much as it is being stretched by excess heat and tension, causing the web to get narrower as it is pulled over the shoes.

PROBLEM: No power is getting to the laminator.

SOLUTION: Make sure there is power at the electrical outlet being used, and make sure both ends of the power cord are firmly engaged. There are fuses inside the laminator, but dead outlets and loose power cord connections are the most common causes of this problem.

PROBLEM: Wavy or rippled sections in the laminate, especially toward the center of the web.

SOLUTION: These "heat wrinkles" are usually caused by excess temperature for the film being used. Always try to use the lowest temperature you can that allows good, clear, lamination with acceptable adhesion.

PROBLEM: General haziness or cloudiness in the film after lamination.

SOLUTION: Increase the temperature. That cloudiness is a function of incomplete adhesion. On a variable speed machine loaded with thicker film, it may be that the film is being run too fast and is not getting enough time on the heat shoes.

PROBLEM: Bubbles in the center of the web and/or film not sticking to the center of an item.

SOLUTION: This problem can be caused by excessive laminating roll pressure. Putting too much pressure on the laminating rollers actually decreases pressure in the center of the web.

The other likely cause of this symptom is worn rollers. For example, if hundreds of thousands of 18-inch wide sheets are laminated on a 38-inch machine, the center of the rollers can get worn down more than the ends of the rollers. In this situation, the laminating rollers should be replaced. The rollers worn in this way are not suitable for use as pull rollers.

For problems not listed here, contact your Ledco Dealer. If the Dealer doesn't know the answer, please ask the dealer to contact Ledco and get back to you.

You are also welcome to contact us directly with any problem at 585-367-2392. Because of the potential volume of support calls, we do encourage the use of the dealer network as much as possible.

6-1 INSTRUCTIONS FOR OPTIONS

NOTE: The footage counter and slitter cannot be installed together.

6-2 FOOTAGE COUNTER

Measures film usage in feet, also available in a metric version.

To measure the use of film with the footage counter:

- Set the wheel of the counter against the roll of film.
- Press the reset button located next to the digital read out.
- The counter will continue to measure the number of feet of film used unless the wheel is lifted off the roll of film.

6-3 SLITTERS

The slitter allows you to quickly and easily cut a laminated item, or group of items which maintain a constant vertical arrangement. For example, a series of identically sized posters may be cut as they exit the machine by positioning the blades on each side of the posters.

WARNING: The blades of the slitter are very sharp. Use extreme caution when using this attachment. Always remove the blades when attaching or detaching the slitter. Always retract the blades when they are not in use or when you are adjusting their position.

Installation:

- Remove the cutting blades from the plastic blade holders. This is done to prevent accidentally slicing the rubber rollers during installation of the slitter and for operator safety.
- Turn the heat/power switch and the drive switch to the OFF position.
- Remove the top supply roll mandrel from the laminator.
- Locate the two accessory mounting holes on the inside of each housing. These are located above the wrap around guard.
- Lower the slitter into position between the housings, blade holders toward the front of the laminator.
- Fasten the slitter between the housings using the four screws provided.
- Slide the blade holders into the desired position by loosening the black plastic knobs.
- Replace the blades in the plastic blade holders with the knife edge facing the FRONT of the machine.

7-1 MAINTENANCE

There are no user-serviceable parts inside the machine. Please refer internal maintenance to qualified personnel.

DANGER: Always use extreme caution when performing maintenance on your machine! Always make sure the machine is unplugged and that there is NO power to the machine when working on or cleaning any part of the unit.

Use extreme caution to avoid Hot Surfaces which may remain hot for a period of time even if there is NO POWER to your machine.

Use extreme caution to avoid pinch points at the nip of rubber rollers.

NEVER have rubber rollers turning while performing maintenance to your machine.

NEVER wear loose clothing, ties or jewelry (which may become entangled in gears or rubber rollers) while operating or performing maintenance on your machine.

MISE EN GARDE: *La prudence est de mise lorsque l'on effectue l'entretien de cette machine.*

S'assurer que le cordon d'alimentation est débranché et que la machine est mise hors tension avant de toucher à des pièces internes.

Prendre garde aux surfaces chaudes. Ces surfaces demeurent chaudes longtemps après que le courant a été coupé.

Tenir les doigts et les objets loin des rouleaux de caoutchouc. Ne jamais faire tourner les rouleaux pendant l'entretien de la machine.

Ne jamais porter de vêtements amples, de cravate ou de bijoux, etc. (ces articles peuvent être happés par les engrenages ou les rouleaux de caoutchouc).

PELIGRO: *Sea extremadamente cuidadoso siempre que realice tareas de mantenimiento en su máquina.*

Asegúrese siempre que la máquina está desenchufada y que no hay NINGUNA energía aplicada a la máquina, mientras esté trabajando con partes internas de la máquina.

Sea extremadamente cuidadoso en evitar superficies calientes, que pueden permanecer calientes durante cierto tiempo, aún después de estar cortada la corriente.

Tenga sumo cuidado en evitar puntos de constricción en las pasadas de los rodillos de goma. Nunca tenga los rodillos de goma en movimiento mientras realiza trabajos de mantenimiento en su máquina.

Nunca vista ropa suelta, corbata o joyas (que pueden ser atrapadas por engranajes o rodillos de goma) mientras está realizando trabajos de mantenimiento en la máquina.

7-2 GENERAL CLEANING

Cleaning the laminator daily or weekly will help prevent dirt or adhesive build-up on the rubber rollers and heat shoes and will improve the performance of the unit especially if you have a dusty work environment

7-3 CLEANING THE HEAT SHOES

During normal use, excess adhesive from the film will often cling to the heat shoes, especially near the edges. Film coating powders can also build up on the shoes, and will tend to increase friction between the film and the shoes. This type of build-up may not be visible, and it may adversely affect lamination in a number of ways. Film squealing loudly as it passes over the shoe can sometimes be a symptom of this problem.

TURN OFF and UNPLUG THE MACHINE. Using a clean, soft, dry cloth, gently rub the adhesive or other contaminants off the shoes. Never use any abrasive material or rub too hard on the shoes, because you may remove the Teflon coating.

You may dampen your cleaning cloth with soapy water or a mild water-based cleaning solution, but make sure you carefully insulate your hands from possible steam burns if you do this. The steam formed when water hits the hot surface can penetrate both the cleaning cloth and your gloves.

7-4 CLEANING THE RUBBER ROLLERS

Both the laminating rollers and the pull rollers need regular cleaning. Collectively these are referred to as the rubber rollers.

To clean the laminating rollers:

1. Use the REVERSE switch to slightly reposition the laminating rollers so that you can clean the entire surface on each roller by sections. The REVERSE switch is a momentary switch. The rollers will stop as soon as you take your finger off the button. Don't try to clean the rollers while they are turning. Never operate the rollers with your hands near the nip.
2. **TURN OFF and UNPLUG THE MACHINE.**
3. Clean the rubber rollers with a mildly abrasive cleaning pad such as the white Scotch Brite (Trademark of 3M) pad which may be purchased in the household section of your grocery store (the green pads are too abrasive). Use "COOL CLEAN" to clean the rollers (available through your LEDCO dealer). Rub firmly but do not scrub the rollers vigorously as this might mar the surface. Do not use sharp metal objects or steel wool as these will also mar the rollers.
4. Repeat step 1-3 until entire roll surface has been cleaned.

WARNING: NEVER CLEAN THE ROLLERS WHILE THEY ARE TURNING. The rollers may catch your fingers and cause injury, or they may catch your cleaning materials and damage the laminator. **UNPLUG THE POWER CORD WHILE CLEANING THE ROLLERS OR PERFORMING OTHER MAINTENANCE ON THE MACHINE.**

MISE EN GARGE: Ne jamais nettoyer les rouleaux pendant qu'ils tournent afin d'éviter de se blesser et d'empêcher que le produit de nettoyage n'endommage l'intérieur de la machine. Débrancher le cordon d'alimentation avant le nettoyage ou tout autre travail d'entretien. Nettoyer d'abord la partie apparente des rouleaux, puis, à l'aide de la commande de marche arrière, les faire tourner de façon à pouvoir en nettoyer toute la surface. Faire tourner les rouleaux le plus lentement possible pour qu'il soit facile de les immobiliser à l'endroit voulu. Ne pas approcher les mains ou les vêtements des rouleaux en rotation. Débrancher à nouveau la machine avant de poursuivre le nettoyage.

AVERTENCIA: Nunca limpie los rodillos de goma mientras estén girando. Al estar girando, los rodillos pueden atrapar sus dedos y lastimarlos, o pueden atrapar sus artículos para limpieza y danar el plastificador. Desenchufe el cordón eléctrico mientras está limpiando los rodillos, o realizando otras tareas de mantenimiento en la máquina. Gire los rodillos por mano. Limpie una sección de los rodillos, luego enchufe la máquina y use el botón de marcha atrás para girar los rodillos y limpiar la sección siguiente. Establezca una velocidad muy baja, para controlar la rotación más fácilmente. Mantenga las manos y la ropa alejadas de los rodillos mientras están girando. Desenchufe la máquina otra vez antes de continuar con la limpieza.

Clean the rubber rollers with a mildly abrasive cleaning pad such as a white Scotch Brite (Trademark of 3M) pad which may be purchased in the household section of your grocery store (the green pads are too abrasive). Use mildly soapy water to clean the rollers. Rub firmly but do not scrub the rollers vigorously as this might mar the surface. Do not use sharp metal objects or steel wool as these will also mar the rollers.

The pull rollers should also be cleaned in the same manner. **TURN OFF** and **UNPLUG THE MACHINE** and **turn the rollers by hand**. The pull rollers are easier to clean because they are more accessible, and because they should not have any adhesive on them. Be sure to reposition and secure the upper heat shoe before beginning to laminate.

7-5 LUBRICATION

Drive Chain

The Drive Chain and sprockets on all models should receive a light coat of gear lube or heavy grease (preferably lithium grease) after each 1000 hours of operation.

RIGHT SIDE PANEL

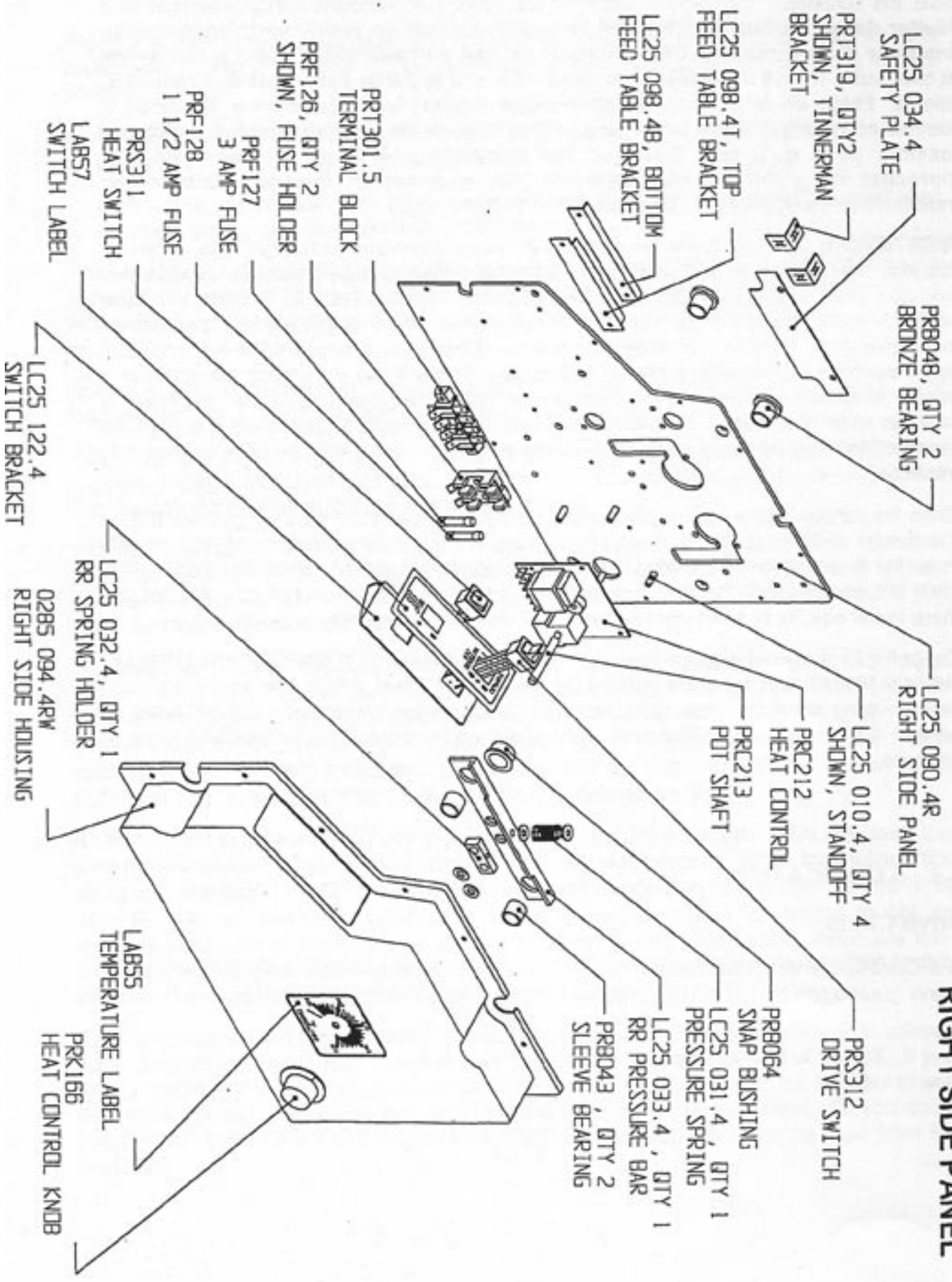

LEFT SIDE PANEL

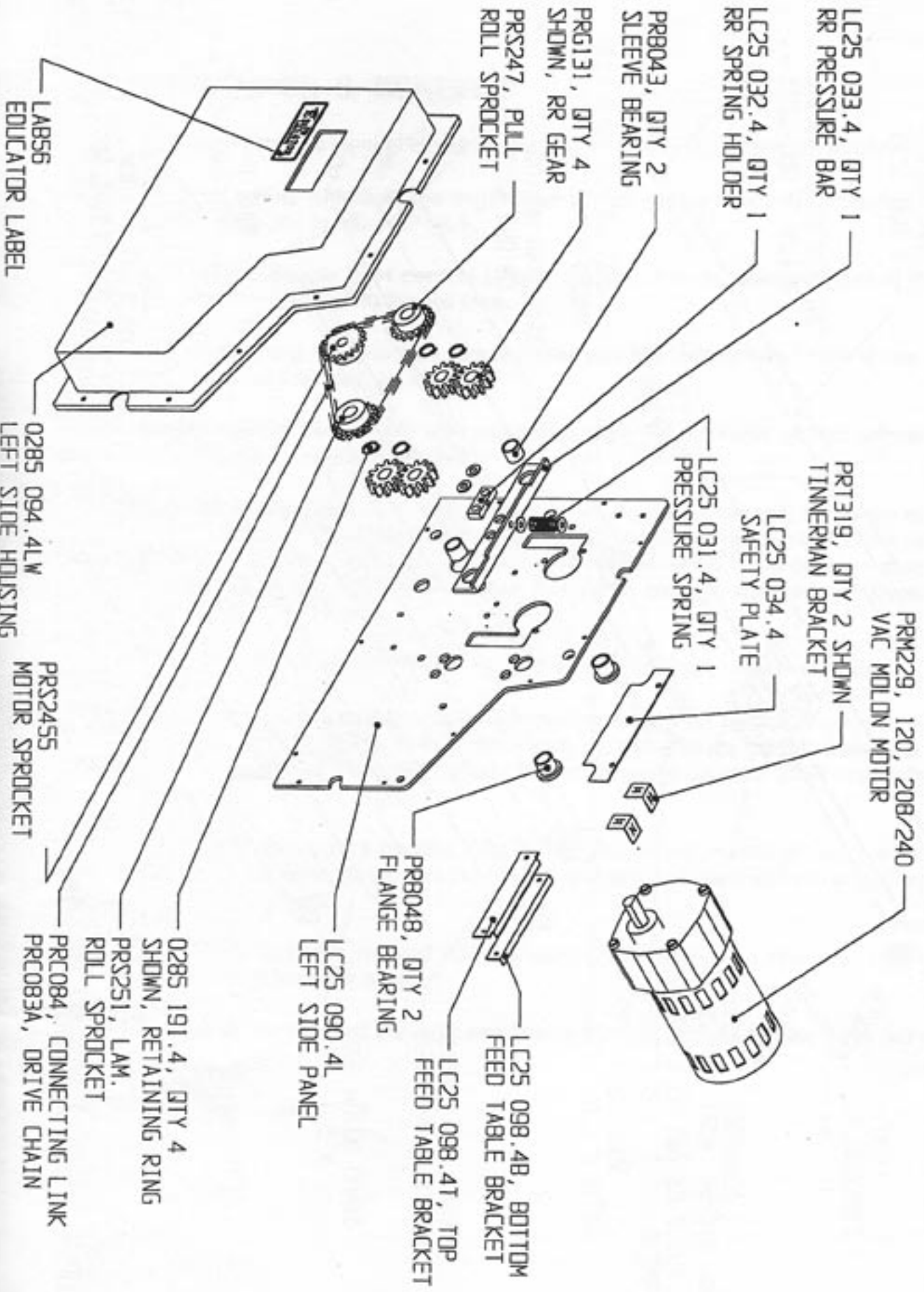

MOTOR COVER & HEAT SHOES

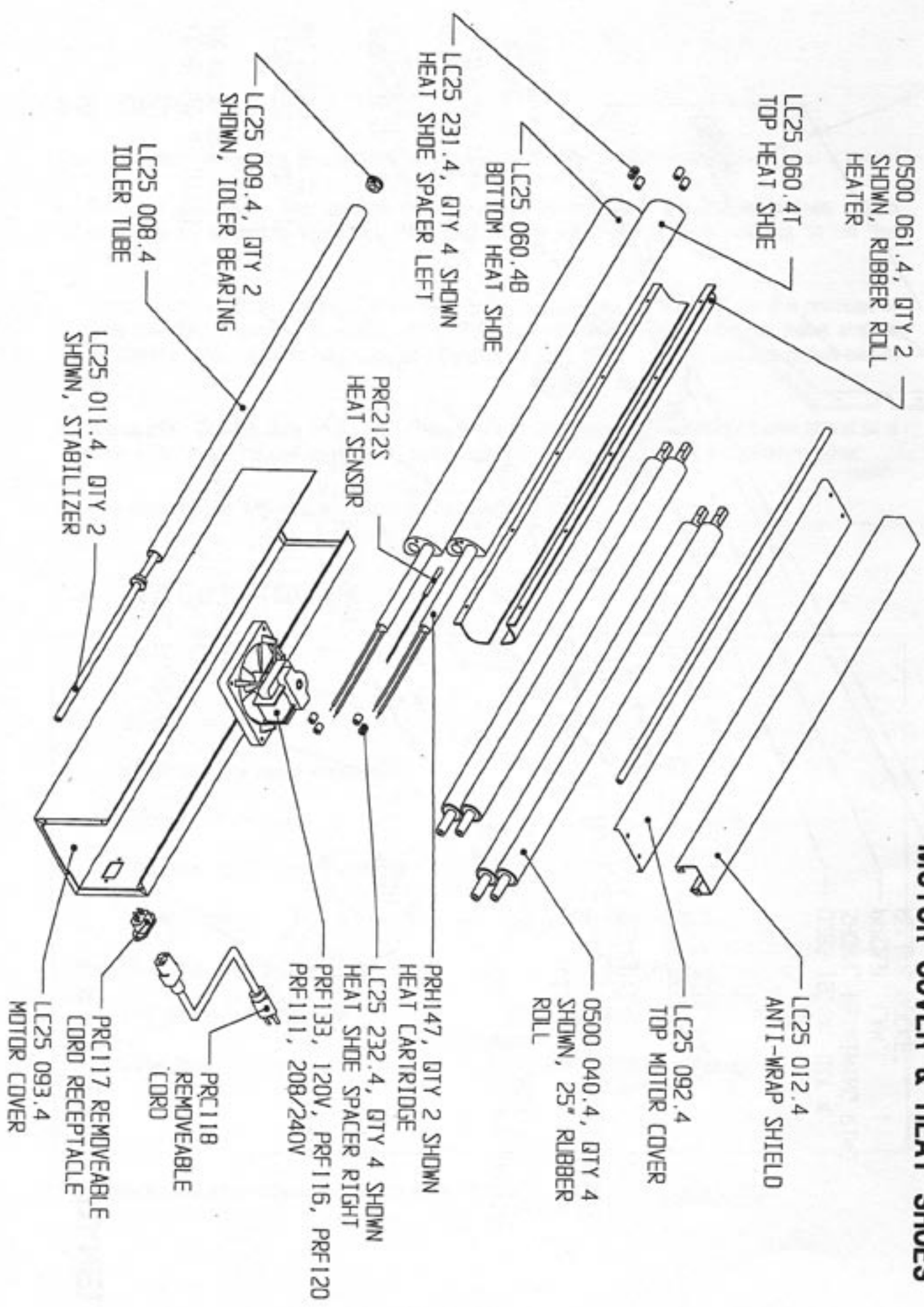

EDUCATOR 120 VAC WIRING DIAGRAM PRM229 MOLON GEARMOTOR

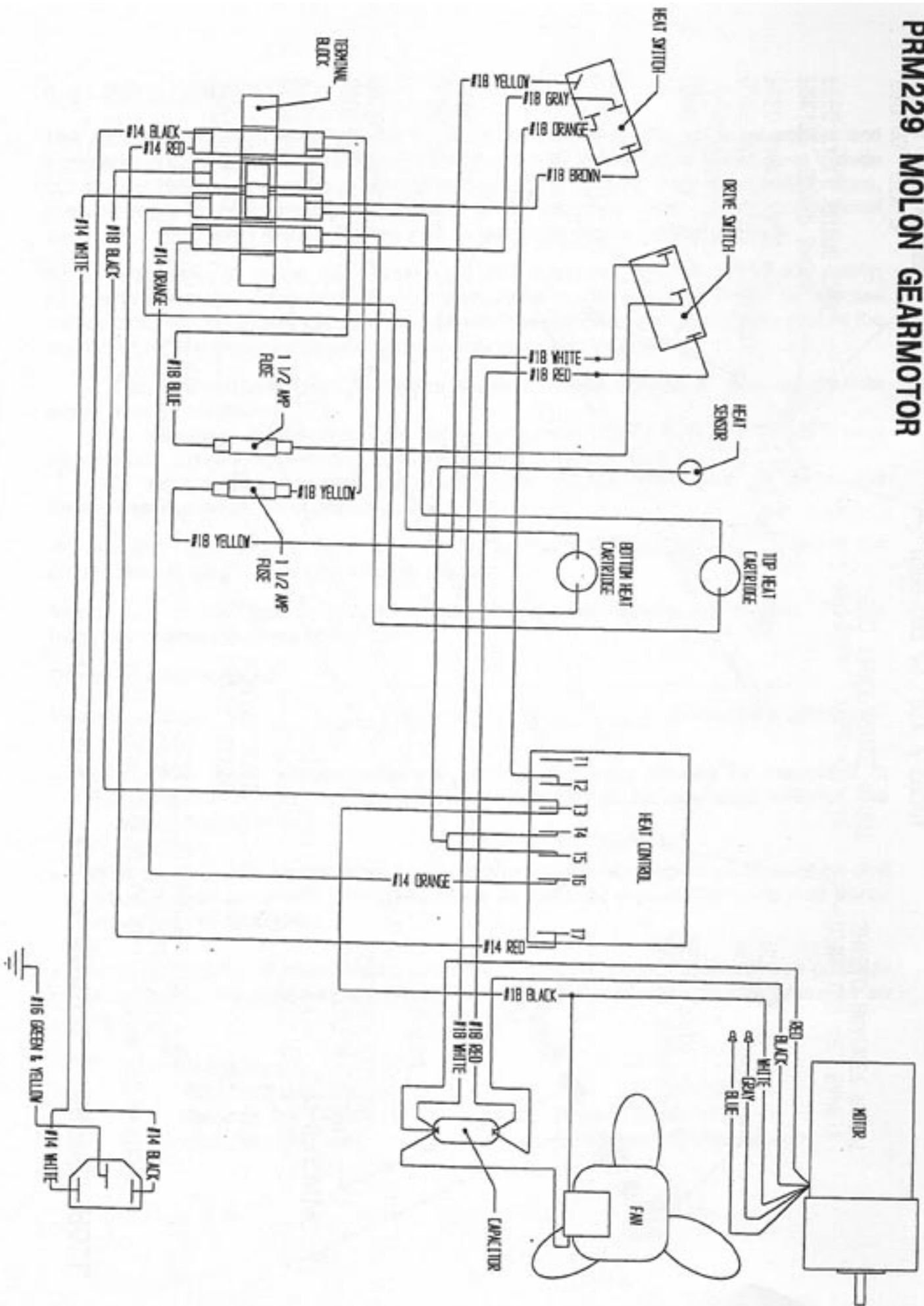

EDUCATOR 208/240 VAC WIRING DIAGRAM PRM229 MOLDN GEARMOTOR

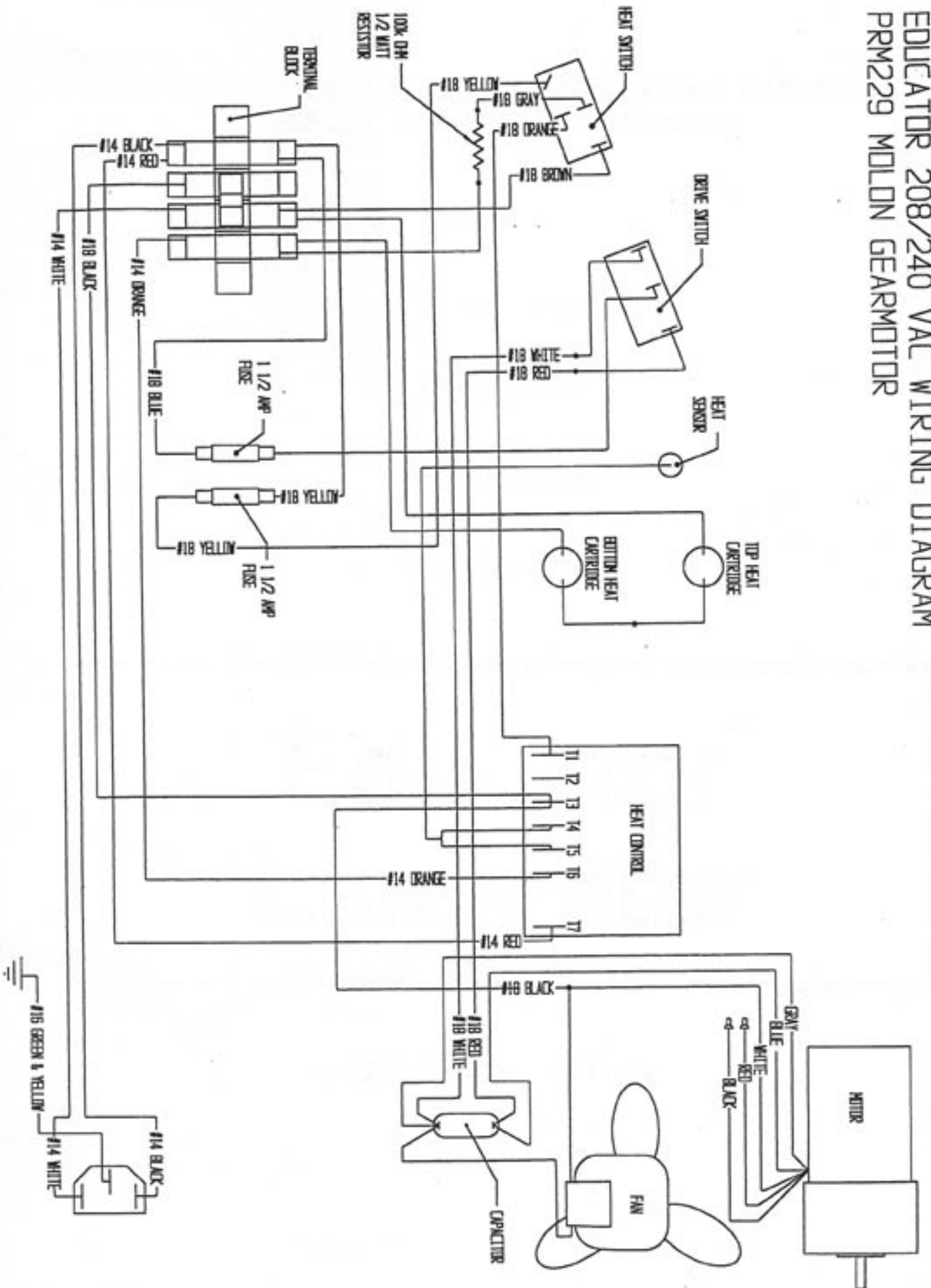

**WHILE UNPACKING YOUR
MACHINE, BE SURE TO LIFT THE
MACHINE OUT OF THE BOX
CAREFULLY.**

**USE THE HANDLES TO LIFT BOTH
ENDS OF THE MACHINE OUT OF
THE BOX AS EVEN AS POSSIBLE TO
AVOID BREAKING OFF THE HEAT
CONTROL KNOB**

MANUAL ADDENDUM

Your machine has been delivered to you with new "universal" style supply roll mandrels. They will operate exactly as described in the operators manual with the exception that there is no difference between "top" or "bottom" mandrel assemblies.

Lamination film core sizes may vary from supplier to supplier. If you experience a "loose" roll of film and the mandrel seems to not be gripping your roll of film properly, simply raise or "bend" the two small brass gripper dogs upward away from the supply roll body to provide extra gripping power.

